

## Non-commutative Desingularization of Determinantal Varieties, II: Arbitrary Minors

Ragnar-Olaf Buchweitz<sup>1</sup>, Graham J. Leuschke<sup>2</sup>, and Michel Van den Bergh<sup>3</sup>

<sup>1</sup>Department of Computer and Mathematical Sciences, University of Toronto Scarborough, Toronto, ON, Canada M1C 1A4, <sup>2</sup>Department of Mathematics, Syracuse University, Syracuse, NY 13244, USA, and <sup>3</sup>Departement WNI, Universiteit Hasselt, 3590 Diepenbeek, Belgium

*Correspondence to be sent to: e-mail: gjleusch@syr.edu*

In our paper "Non-commutative desingularization of determinantal varieties I", we constructed and studied non-commutative resolutions of determinantal varieties defined by maximal minors. At the end of the introduction, we asserted that the results could be generalized to determinantal varieties defined by non-maximal minors, at least in characteristic zero. In this paper, we prove the *existence* of non-commutative resolutions in the general case in a manner which is still characteristic free, and carry out the explicit description by generators and relations in characteristic zero. As an application of our results, we prove that there is a fully faithful embedding between the bounded derived categories of the two canonical (commutative) resolutions of a determinantal variety, confirming a well-known conjecture of Bondal and Orlov in this special case.

### 1 Introduction

Let  $K$  be a field and let  $F, G$  be two  $K$ -vector spaces of ranks  $m$  and  $n$ , respectively. We take unadorned tensor products over  $K$  and denote by  $(-)^{\vee}$  the  $K$ -dual.

Received April 16, 2015; Accepted June 10, 2015  
Communicated by Corrado De Concini

Put  $H = \text{Hom}_K(G, F)$ , viewed as the affine variety of  $K$ -rational points of  $\text{Spec } S$ , where  $S = \text{Sym}_K(H^\vee)$  is isomorphic to a polynomial ring in  $mn$  indeterminates. The *generic  $S$ -linear map*  $\varphi: G \otimes S \rightarrow F \otimes S$  corresponds to multiplication by the generic  $(m \times n)$ -matrix comprising those indeterminates.

Fix a non-negative integer  $l < \min(m, n)$ , and let  $\text{Spec } R$  be the locus in  $\text{Spec } S$  where  $\wedge^{l+1} \varphi = 0$ . Then  $R$  is the quotient of  $S$  by the ideal of  $(l+1)$ -minors of the generic  $(m \times n)$ -matrix. It is a classical result that  $R$  is Cohen–Macaulay of codimension  $(n-l)(m-l)$ , with singular locus defined by the  $l$ -minors of the generic matrix; in particular,  $R$  is smooth in codimension 2.

In this paper, we consider some natural  $R$ -modules. For a partition  $\alpha = (\alpha_1, \dots, \alpha_r)$  and a vector space  $V$ , write

$$\wedge^\alpha V = \wedge^{\alpha_1} V \otimes \cdots \otimes \wedge^{\alpha_r} V.$$

Let  $\alpha'$  denote the conjugate partition of  $\alpha$ , and  $\wedge^{\alpha'} \varphi^\vee: \wedge^{\alpha'} F^\vee \otimes S \rightarrow \wedge^{\alpha'} G^\vee \otimes S$  the natural map induced by  $\varphi$ . Define

$$T_\alpha = \text{image} \left( \wedge^{\alpha'} F^\vee \otimes R \xrightarrow{\left(\wedge^{\alpha'} \varphi^\vee\right) \otimes R} \wedge^{\alpha'} G^\vee \otimes R \right).$$

Let  $B_{u,v}$  be the set of all partitions with at most  $u$  rows and at most  $v$  columns and set

$$T = \bigoplus_{\alpha \in B_{l,m-l}} T_\alpha \quad \text{and} \quad E = \text{End}_R(T).$$

Our first main result generalizes the case  $l = m - 1$  [5, Theorem A], and shows that general determinantal varieties admit a *non-commutative desingularization* in the following sense.

**Theorem A.** For  $m \leq n$ , the endomorphism ring  $E = \text{End}_R(T)$  is maximal Cohen–Macaulay as an  $R$ -module, and has moreover finite global dimension. In particular,  $T_\alpha$  is a maximal Cohen–Macaulay  $R$ -module for each  $\alpha \in B_{l,m-l}$ .  $\square$

If  $m = n$ , then  $R$  is Gorenstein; in this case,  $E$  is an example of a *non-commutative crepant resolution* as defined in [22].

The  $R$ -module  $T_\alpha$  is in general far from indecomposable. Assume for a moment that  $K$  has characteristic zero and denote by  $L^\alpha V$  the irreducible  $\text{GL}(V)$ -module with

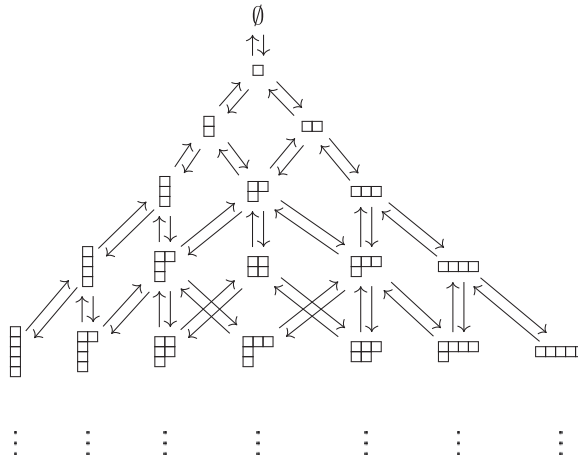

Fig. 1. The Young quiver.

highest weight  $\alpha$  (a.k.a. Schur module [24]). It then follows from the Pieri rule that  $\wedge^{\alpha'} V = L^\alpha V \oplus W$ , where  $W$  is a direct sum of certain  $L^\beta V$  with  $\beta < \alpha$  for the natural order on partitions. Hence, if we put

$$N_\alpha = \text{image} \left( L^\alpha(F^\vee) \otimes R \xrightarrow{(L^\alpha(\varphi^\vee)) \otimes R} L^\alpha(G^\vee) \otimes R \right),$$

then in characteristic zero  $T_\alpha$  is a direct sum of  $N_\beta$  for  $\beta \leq \alpha$  with  $N_\alpha$  appearing with multiplicity 1. In particular, we obtain that  $N_\alpha$  is maximal Cohen–Macaulay. This is false in small characteristic; see Remark 3.7 where we make the connection with the work of Weyman [24, Section 6].

If we set  $N = \bigoplus_{\alpha \in B_{l,m-l}} N_\alpha$  and  $A = \text{End}_R(N)$ , then  $A$  is Morita equivalent to  $E = \text{End}_R(T)$ . Clearly, Theorem A remains valid in characteristic zero if we replace  $E$  by  $A$ . Furthermore, we have the following description by generators and relations of the non-commutative desingularization  $A$ . Write  $\alpha \nearrow \beta$  if  $\beta$  is obtained by adding a box to  $\alpha$ .

**Theorem B** (Theorem 6.9). Assume that  $K$  has characteristic zero and  $m - l > 1$ . As a  $K$ -algebra,  $A$  is isomorphic to the bound path algebra of the truncated Young quiver (Figure 1) having vertices  $\alpha \in B_{l,m-l}$  and arrows  $\alpha \rightarrow \beta$  indexed by bases for

$$\begin{cases} F^\vee & \text{if } \alpha \nearrow \beta \text{ and} \\ G & \text{if } \beta \nearrow \alpha, \end{cases}$$

with vector spaces of relations between two vertices  $\alpha, \gamma \in B_{l,m-l}$  given by

$$\left\{ \begin{array}{ll} \mathrm{Sym}_2 F^\vee & \text{if } \gamma \nearrow \nearrow \alpha, \text{ two boxes in a column,} \\ \wedge^2 F^\vee & \text{if } \gamma \nearrow \nearrow \alpha, \text{ two boxes in a row,} \\ \mathrm{Sym}_2 F^\vee \oplus \wedge^2 F^\vee \cong F^\vee \otimes F^\vee & \text{if } \gamma \nearrow \nearrow \alpha, \text{ two disconnected boxes,} \\ F^\vee \otimes G & \text{if } \alpha \neq \gamma \text{ and } \alpha \nearrow \beta, \gamma \nearrow \beta, \text{ for some } \beta \text{ with } \beta_1 \leq m-l, \\ (F^\vee \otimes G)^{\oplus(t(\alpha)-1)} & \text{if } \alpha = \gamma, \\ \mathrm{Sym}_2 G & \text{if } \alpha \nearrow \nearrow \gamma, \text{ two boxes in a column,} \\ \wedge^2 G & \text{if } \alpha \nearrow \nearrow \gamma, \text{ two boxes in a row,} \\ \mathrm{Sym}_2 G \oplus \wedge^2 G \cong G \otimes G & \text{if } \alpha \nearrow \nearrow \gamma, \text{ two disconnected boxes,} \end{array} \right.$$

where  $t(\alpha)$  is the number of ways to add a box to  $\alpha$  without making any row longer than  $m-l$ . □

Note that the representations defining the listed relations, for example,  $\mathrm{Sym}_2 F^\vee \subset F^\vee \otimes F^\vee$ , are *not* induced by the obvious diagonal inclusions; there are some non-trivial scalars appearing. See Section 7.

Now let  $K$  be general again. We have taken care to state Theorems A and B in algebraic language but as in [5] the proofs proceed by invoking algebraic geometry, that is, by constructing a suitable tilting bundle on the Springer resolution of  $\mathrm{Spec} R$ .

Write  $\mathbb{G} = \mathrm{Grass}(l, F) \cong \mathrm{Grass}(l, m)$  for the Grassmannian variety of  $l$ -dimensional subspaces of  $F$ , and let  $\pi: \mathbb{G} \rightarrow \mathrm{Spec} K$  be the structure morphism to the base scheme  $\mathrm{Spec} K$ . On  $\mathbb{G}$ , we have a tautological exact sequence of vector bundles

$$0 \rightarrow \mathcal{R} \rightarrow \pi^* F^\vee \rightarrow \mathcal{Q} \rightarrow 0 \tag{1.1}$$

whose fiber above a point  $(V \subset F) \in \mathbb{G}$  is the short exact sequence  $0 \rightarrow (F/V)^\vee \rightarrow F^\vee \rightarrow V^\vee \rightarrow 0$ . In [6], we proved that the  $\mathcal{O}_{\mathbb{G}}$ -module

$$\mathcal{T}_0 = \bigoplus_{\alpha \in B_{l,m-l}} \wedge^{\alpha'} \mathcal{Q}$$

is a tilting bundle on  $\mathbb{G}$ . From this, we derive our main geometric result as follows. Set  $\mathcal{Y} = \mathbb{G} \times_{\mathrm{Spec} K} H$ , with the canonical projections  $p: \mathcal{Y} \rightarrow \mathbb{G}$  and  $q: \mathcal{Y} \rightarrow H$ . Define the *incidence variety*

$$\mathcal{Z} = \{(V, \theta) \in \mathbb{G} \times_{\mathrm{Spec} K} H \mid \mathrm{image} \theta \subset V\} \subseteq \mathcal{Y}$$

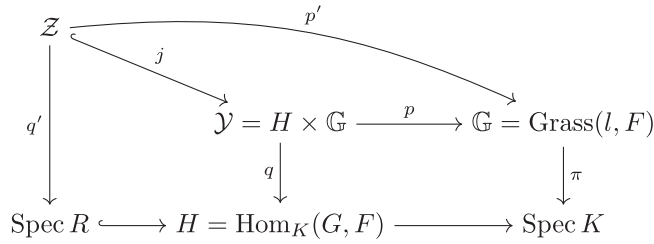

Fig. 2. The schemes and maps of interest.

and denote by  $j$  the natural inclusion  $\mathcal{Z} \rightarrow \mathcal{Y}$ . The composition  $q' = qj: \mathcal{Z} \rightarrow H$  is then a birational isomorphism from  $\mathcal{Z}$  onto its image  $q'(\mathcal{Z}) = \text{Spec } R$ , while  $p' = pj: \mathcal{Z} \rightarrow \mathbb{G}$  is a vector bundle (with zero section  $\theta = 0$ ). Figure 2 summarizes the schemes and maps we have defined. We call  $\mathcal{Z}$  the *Springer resolution* of  $\text{Spec } R$ .

**Theorem C.** The  $\mathcal{O}_{\mathcal{Z}}$ -module

$$\mathcal{T} = p'^* \left( \bigoplus_{\alpha \in B_{l,m-1}} \wedge^{\alpha'} \mathcal{Q} \right)$$

is a classical tilting bundle on  $\mathcal{Z}$ , that is,

- (i)  $\mathcal{T}$  classically generates the derived category  $\mathcal{D}^b(\text{coh } \mathcal{Z})$ , in that the smallest thick subcategory of  $\mathcal{D}^b(\text{coh } \mathcal{Z})$  containing  $\mathcal{T}$  is  $\mathcal{D}^b(\text{coh } \mathcal{Z})$  and
- (ii)  $\text{Hom}_{\mathcal{D}^b(\text{coh } \mathcal{Z})}(\mathcal{T}, \mathcal{T}[i]) = 0$  for  $i \neq 0$ .

Furthermore, we have

- (iii)  $T_\alpha \cong \mathbf{R}q'_* \wedge^{\alpha'} \mathcal{Q}$  for each  $\alpha \in B_{l,m-1}$ , so that  $T \cong \mathbf{R}q'_* \mathcal{T}$  and
- (iv)  $E \cong \text{End}_{\mathcal{O}_{\mathcal{Z}}}(\mathcal{T})$ . □

The proofs of Theorems A and C are substantially simpler than the corresponding ones in [5], even in the case treated there of maximal minors.

As  $H = \text{Hom}_K(G, F)$  is canonically isomorphic to  $\text{Hom}_K(F^\vee, G^\vee)$ , we obtain a second Springer resolution  $q'_2: \mathcal{Z}_2 \rightarrow \text{Spec } R$  by replacing  $(F, G)$  with  $(G^\vee, F^\vee)$ . Put  $\hat{\mathcal{Z}} = \mathcal{Z} \times_H \mathcal{Z}_2$ . As an application of Theorem C, we prove the following.

**Theorem D.** If  $m \leq n$ , then the Fourier–Mukai transform with kernel  $\mathcal{O}_{\hat{\mathcal{Z}}}$  induces a fully faithful embedding  $\text{FM}: \mathcal{D}^b(\text{coh } \mathcal{Z}) \hookrightarrow \mathcal{D}^b(\text{coh } \mathcal{Z}_2)$ . If  $m = n$ , then FM is an equivalence. □

A general conjecture by Bondal and Orlov [4] asserts that a flip between algebraic varieties induces a fully faithful embedding between their derived categories. It is not hard to see that the birational map  $\mathcal{Z}_2 \dashrightarrow \mathcal{Z}$  is a flip, so we obtain a confirmation of the Bondal–Orlov conjecture in this special case.

The first half of the paper is characteristic-free. We include a short section recalling the results we need from [6], as well as some background on characteristic-free versions of the Cauchy formula and Littlewood–Richardson rule. These are used to prove Theorem C, and as a consequence Theorem A, in Section 3. Section 4 contains the proof of Theorem D.

In the second half, we specialize to characteristic zero. Section 5 contains the calculation of the Ext groups between the simple  $A$ -modules, which will be used in Section 6 to construct an isomorphism between  $A$  and the path algebra of the truncated Young quiver  $\mathbb{Y}_{l,m-l}$  in Theorem B. The relations on the path algebra of  $\mathbb{Y}_{l,m-l}$  are induced by relations between certain maps occurring in Pieri’s formula which were introduced by Olver [18]; in Section 7, we show how to compute these relations and thereby the scalars appearing in Theorem B. The first non-trivial example  $(m, n, l) = (4, 4, 2)$  is worked out in Section 8.

We include an Appendix giving an alternative description of the non-commutative desingularization as a “quiverized Clifford algebra” as in our earlier paper [5].

Since the original version of this article was posted on the arXiv, similar results have been obtained by other authors [2, 7, 8, 25].

## 2 Preliminaries

We recall two results from [6]. Recall that we write  $L^\alpha$  for the Schur functors; our conventions are that  $L^{(t)}V = \mathrm{Sym}_t V$  and  $L^{(1^t)}V = \bigwedge^t V$ . (This convention differs from that in [24]. Our indexing is such that  $L^\alpha$  has highest weight  $\alpha$ .) The functors  $L^\alpha$  are defined for all *dominant weights*, that is, weakly decreasing sequences of integers. A *partition* is a dominant weight with non-negative entries.

**Theorem 2.1** ([6, Theorem 1.2]). The  $\mathcal{O}_{\mathbb{G}}$ -module

$$\mathcal{T}_0 = \bigoplus_{\alpha \in B_{l,m-l}} \bigwedge^{\alpha'} \mathcal{Q}$$

is a classical tilting bundle on  $\mathbb{G}$ , that is,

- (i)  $\mathcal{T}_0$  classically generates the derived category  $\mathcal{D}^b(\text{coh } \mathbb{G})$ , in that  $\mathcal{D}^b(\text{coh } \mathbb{G})$  is the smallest thick subcategory of itself containing  $\mathcal{T}_0$  and
- (ii)  $\text{Hom}_{\mathcal{D}^b(\text{coh } \mathbb{G})}(\mathcal{T}_0, \mathcal{T}_0[i]) = 0$  for  $i \neq 0$ . □

**Proposition 2.2** ([6, Proposition 1.3]). Let  $\alpha \in B_{l,m-l}$  and let  $\delta$  be any partition. Then for all  $i > 0$  one has

$$H^i(\mathbb{G}, (\bigwedge^{\alpha'} \mathcal{Q})^\vee \otimes_{\mathcal{O}_{\mathbb{G}}} L^\delta \mathcal{Q}) = 0. \quad \square$$

We also state for easy reference the following characteristic-free versions of the Cauchy formula and the Littlewood–Richardson rule. See [24, Theorems 2.3.2 and 2.3.4].

**Theorem 2.3** (Boffi [3], Doubilet–Rota–Stein [9]). Let  $V$  and  $W$  be  $K$ -vector spaces and let  $\alpha$  and  $\beta$  be dominant weights.

- (i) There is a natural filtration on  $\text{Sym}_t(V \otimes W)$  whose associated graded object is a direct sum with summands tensor products  $L^\gamma V \otimes L^{\gamma'} W$  of Schur functors.
- (ii) There is a natural filtration on  $\bigwedge^t(V \otimes W)$  whose associated graded object is a direct sum with summands tensor products  $L^\gamma V \otimes (L^{\gamma'} W^\vee)^\vee$  of Schur functors.
- (iii) There is a natural filtration on  $L^\alpha V \otimes L^\beta V$  whose associated graded object is a direct sum of Schur functors  $L^\gamma V$ . The  $\gamma$  that appear, and their multiplicities, can be computed using the usual Littlewood–Richardson rule.

If  $\text{char } K = 0$ , then the filtrations above degenerate to direct sums. Note that in characteristic zero  $(L^{\gamma'} W^\vee)^\vee \cong L^{\gamma'} W$ . □

### 3 A Tilting Bundle on the Resolution

To prove Theorem C, keep all the notation introduced there. One easily verifies that

$$\mathcal{Z} = \underline{\text{Spec}} (\text{Sym}_{\mathbb{G}}(G \otimes \mathcal{Q}));$$

indeed, a closed point of the right-hand side consists of a pair  $(V \subset F, \theta)$ , where  $(V \subset F) \in \mathbb{G}$  and  $\theta$  is an element of the fiber of  $(G \otimes \mathcal{Q})^\vee$  over the point  $(V \subset F)$ . That fiber is

$$(G \otimes V^\vee)^\vee = \text{Hom}_K(G, V) \subset \text{Hom}_K(G, F),$$

so the pair  $(V, \theta)$  is precisely a point of  $\mathcal{Z}$ .

We have  $\mathcal{T}_0 = \bigoplus_{\alpha \in B_{l,m-l}} \wedge^{\alpha'} \mathcal{Q}$ , a tilting bundle on  $\mathbb{G}$  by Theorem 2.1. Set  $\mathcal{T} = p^* \mathcal{T}_0$ , a vector bundle on  $\mathcal{Z}$ .

**Proposition 3.1.** The  $\mathcal{O}_{\mathcal{Z}}$ -module  $\mathcal{T} = p^* \mathcal{T}_0$  is a tilting bundle on  $\mathcal{Z}$ . □

**Proof.** Since  $\mathcal{T}_0$  classically generates  $\mathcal{D}^b(\text{coh } \mathbb{G})$  and  $p$  is an affine morphism, it is easy to see that  $\mathcal{T}$  classically generates  $\mathcal{D}^b(\text{coh } \mathcal{Z})$ , so it remains to prove Ext-vanishing. We have

$$\text{Ext}_{\mathcal{O}_{\mathcal{Z}}}^i(\mathcal{T}, \mathcal{T}) = H^i(\mathbb{G}, \text{Sym}_{\mathbb{G}}(G \otimes \mathcal{Q}) \otimes_{\mathcal{O}_{\mathbb{G}}} \text{End}_{\mathcal{O}_{\mathbb{G}}}(\mathcal{T}_0))$$

and hence we need to prove that

$$\text{Sym}_{\mathbb{G}}(G \otimes \mathcal{Q}) \otimes_{\mathcal{O}_{\mathbb{G}}} \text{Hom}_{\mathcal{O}_{\mathbb{G}}}(\wedge^{\alpha'} \mathcal{Q}, \wedge^{\beta'} \mathcal{Q}) \quad (3.1)$$

has vanishing higher cohomology for  $\alpha, \beta \in B_{l,m-l}$ .

Using Theorem 2.3, we find that (3.1) has a filtration whose associated graded object is a direct sum of vector bundles of the form

$$(\wedge^{\alpha'} \mathcal{Q})^{\vee} \otimes_{\mathcal{O}_{\mathbb{G}}} L^{\delta} \mathcal{Q}, \quad (3.2)$$

where  $\alpha \in B_{l,m-l}$  and  $\delta$  is some partition containing  $\beta$ . It now suffices to invoke Proposition 2.2. ■

To prove the rest of Theorem C, we shall show that  $\text{End}_R(\mathbf{R}q'_* \mathcal{T}) = \mathbf{R}q'_* \text{End}_{\mathcal{O}_{\mathcal{Z}}}(\mathcal{T})$ , and that the latter is MCM and has finite global dimension. Put

$$\mathcal{E} = \text{End}_{\mathcal{O}_{\mathcal{Z}}}(\mathcal{T}),$$

and let  $\omega_{\mathcal{Z}}$  be the dualizing sheaf of  $\mathcal{Z}$ .

**Lemma 3.2.** Assume  $m \leq n$ . Then  $\text{Ext}_{\mathcal{O}_{\mathcal{Z}}}^i(\mathcal{E}, \omega_{\mathcal{Z}}) = 0$  for all  $i > 0$ . □

**Proof.** We have  $\mathcal{E} = p'^* \mathcal{E}_0$ , with  $\mathcal{E}_0 = \text{Hom}_{\mathcal{O}_{\mathbb{G}}}(\mathcal{T}_0, \mathcal{T}_0)$ . Substituting this and using the fact that  $\mathcal{E}_0$  is self-dual, we find

$$\begin{aligned} \text{Ext}_{\mathcal{O}_{\mathcal{Z}}}^i(\mathcal{E}, \omega_{\mathcal{Z}}) &= \text{Ext}_{\mathcal{O}_{\mathcal{Z}}}^i(p'^* \mathcal{E}_0, \omega_{\mathcal{Z}}) \\ &= \text{Ext}_{\mathcal{O}_{\mathbb{G}}}^i(\mathcal{E}_0, p'_* \omega_{\mathcal{Z}}) \\ &= H^i(\mathbb{G}, \mathcal{E}_0 \otimes_{\mathcal{O}_{\mathbb{G}}} p'_* \omega_{\mathcal{Z}}). \end{aligned}$$



Hence, to continue we must be able to compute  $p'_*\omega_Z$ . Since  $Z = \underline{\text{Spec}}(\text{Sym}_{\mathbb{G}}(G \otimes Q))$ , the standard expression, see, for example, [11, Exercise III.8.4], for the dualizing sheaf of a symmetric algebra gives

$$p'_*\omega_Z = \omega_{\mathbb{G}} \otimes_{\mathcal{O}_Z} \bigwedge^{ln}(G \otimes Q) \otimes_{\mathcal{O}_Z} \text{Sym}_{\mathbb{G}}(G \otimes Q).$$

Furthermore, the sheaf  $\Omega_{\mathbb{G}}$  of differential forms on  $\mathbb{G}$  is known to be given by  $\Omega_{\mathbb{G}} = Q^{\vee} \otimes_{\mathcal{O}_{\mathbb{G}}} \mathcal{R}$ , where  $\mathcal{R}$  is the tautological sub-bundle of  $\pi^*F^{\vee}$  as in (1.1). Hence,  $\omega_{\mathbb{G}} = \bigwedge^{ln}(Q^{\vee} \otimes_{\mathcal{O}_{\mathbb{G}}} \mathcal{R})$  and so

$$p'_*\omega_Z = \bigwedge^{ln}(Q^{\vee} \otimes_{\mathcal{O}_{\mathbb{G}}} \mathcal{R}) \otimes_{\mathcal{O}_{\mathbb{G}}} \bigwedge^{ln}(G \otimes Q) \otimes_{\mathcal{O}_{\mathbb{G}}} \text{Sym}_{\mathbb{G}}(G \otimes Q).$$

Rewriting all the exterior powers in terms of  $Q$ , we find

$$\begin{aligned} \bigwedge^{ln}(Q^{\vee} \otimes \mathcal{R}) \otimes \bigwedge^{ln}(G \otimes Q) &= (\bigwedge^l Q)^{-m+l} \otimes (\bigwedge^{m-l} \mathcal{R})^l \otimes (\bigwedge^n G)^l \otimes (\bigwedge^l Q)^n \\ &= (\bigwedge^l Q)^{-m+l} \otimes (\bigwedge^m F)^{-l} \otimes (\bigwedge^l Q)^{-l} \otimes (\bigwedge^n G)^l \otimes (\bigwedge^l Q)^n \\ &= (\bigwedge^l Q)^{n-m} \otimes (\bigwedge^m F)^{-l} \otimes (\bigwedge^n G)^l. \end{aligned}$$

So finally

$$\mathcal{E}_0 \otimes_{\mathcal{O}_{\mathbb{G}}} p'_*\omega_Z = (\bigwedge^m F)^{-l} \otimes (\bigwedge^n G)^l \otimes \mathcal{E}_0 \otimes_{\mathcal{O}_{\mathbb{G}}} (\bigwedge^l Q)^{n-m} \otimes_{\mathcal{O}_{\mathbb{G}}} \text{Sym}_{\mathbb{G}}(G \otimes Q).$$

Discarding the copies of the vector spaces  $\bigwedge^m F$  and  $\bigwedge^n G$ , we find a direct sum of vector bundles of the form

$$\bigwedge^{\alpha'} Q^{\vee} \otimes_{\mathcal{O}_{\mathbb{G}}} \bigwedge^{\beta} Q \otimes_{\mathcal{O}_{\mathbb{G}}} (\bigwedge^l Q)^{n-m} \otimes_{\mathcal{O}_{\mathbb{G}}} \text{Sym}_{\mathbb{G}}(G \otimes Q),$$

which (since  $m \leq n$ ) are the subject of Proposition 2.2. ■

Next we verify Theorem C for

$$\bar{E} = \text{End}_{\mathcal{O}_Z}(\mathcal{T}) = \Gamma(Z, \mathcal{E}) \quad \text{and} \quad \bar{T} = \Gamma(Z, \mathcal{T}).$$

Recall the following consequence of tilting (see, e.g., [12]).

**Proposition 3.3.** Assume that  $\mathcal{T}$  is a tilting bundle on a smooth variety  $X$ . Then  $\text{RHom}_{\mathcal{O}_X}(\mathcal{T}, -)$  defines an equivalence of derived categories  $\mathcal{D}^b(\text{coh } X) \cong \mathcal{D}^b(\text{mod } E)$  where  $E = \text{End}_{\mathcal{O}_X}(\mathcal{T})$ . If  $X$  is projective over an affine variety, then  $E$  is finite over its center and has finite global dimension. □

**Proposition 3.4.** Assume  $m \leq n$ . Then

- (i)  $\bar{E} \cong \text{End}_R(\bar{T})$ ;
- (ii)  $\bar{E}$  and  $\bar{T}$  are MCM  $R$ -modules; and
- (iii)  $\bar{E}$  has finite global dimension. □

**Proof.** That  $\bar{E}$  has finite global dimension follows from Propositions 3.1 and 3.3. Since  $\text{Ext}_{\mathcal{O}_{\mathcal{Z}}}^i(\mathcal{T}, \mathcal{T}) = 0$  for  $i > 0$  by Proposition 3.1, the higher direct images of  $\mathcal{E}$  vanish, that is,

$$\mathbf{R}q'_* \mathcal{E} = q'_* \mathcal{E} = \bar{E}.$$

To prove that  $\bar{E}$  is MCM, we must show that  $\text{Ext}_R^i(\bar{E}, \omega_R) = 0$  for  $i > 0$ , where  $\omega_R$  is the dualizing module for  $R$ . Replacing  $\bar{E}$  by  $\mathbf{R}q'_* \mathcal{E}$  and using duality for the proper morphism  $q'$  [24, Theorem 1.2.22], we see that this is equivalent to showing  $\text{Ext}_{\mathcal{O}_{\mathcal{Z}}}^i(\mathcal{E}, q'^! \omega_R) = 0$  for  $i > 0$ . But  $q'^! \omega_R = \omega_{\mathcal{Z}}$  is the dualizing sheaf for  $\mathcal{Z}$ , so Lemma 3.2 implies that  $\bar{E}$  is MCM.

As  $\mathcal{O}_{\mathcal{Z}}$  is a direct summand of  $\mathcal{T}$ , we see that  $\bar{T}$  is a summand of  $\bar{E}$ , whence  $\bar{T}$  is Cohen–Macaulay as well. Furthermore, we have an obvious homomorphism  $i: \text{End}_{\mathcal{O}_{\mathcal{Z}}}(\mathcal{T}) \rightarrow \text{End}_R(\bar{T})$  between reflexive  $R$ -modules, which is an isomorphism on the locus where  $q': \mathcal{Z} \rightarrow \text{Spec } R$  is an isomorphism. The complement of this locus is given by the matrices which have rank  $< 1$ , a subvariety of  $\text{Spec } R$  of codimension  $\geq 2$ . Hence,  $i$  is an isomorphism. ■

Propositions 3.1 and 3.4 imply Theorems A and C provided we can show  $T \cong \bar{T}$ . We do this next. Recall that for a partition  $\alpha$ , we denote

$$N_\alpha = \text{image} \left( L^\alpha(F^\vee) \otimes R \xrightarrow{(L^\alpha(\varphi^\vee)) \otimes R} L^\alpha(G^\vee) \otimes R \right).$$

Set  $\mathcal{N}_\alpha = p'^* L^\alpha \mathcal{Q}$ .

**Proposition 3.5.** With notation as above, we have

$$N_\alpha \cong \Gamma(\mathcal{Z}, \mathcal{N}_\alpha). \quad \square$$

**Proof.** With  $\varphi: G \otimes S \rightarrow F \otimes S$ , the generic map defined over  $S$ , let  $\psi = j^* q^* \varphi$  be the map induced over  $\mathcal{Z}$ . Then the fiber of  $\psi^\vee$  over a point  $(V, \theta)$  factors as

$$F^\vee \rightarrow V^\vee \rightarrow G^\vee,$$

where the first map is the dual of the given inclusion  $V \hookrightarrow F$ . Thus,  $\psi^\vee$  factors as

$$p'^* \pi^* F^\vee \rightarrow p'^* \mathcal{Q} \rightarrow p'^* \pi^* G^\vee.$$

The first map is obviously surjective. The second map is injective since it is a map between vector bundles which is generically injective. Schur functors preserve epimorphisms and monomorphisms of vector bundles [10, Section 8.1], so we get an epi-mono factorization

$$L^\alpha(\psi^\vee): L^\alpha(p'^*\pi^*F^\vee) \longrightarrow L^\alpha p'^*Q \longrightarrow L^\alpha(p'^*\pi^*G^\vee).$$

To prove the claim, it is clearly sufficient to show that the first map remains an epimorphism after applying  $q'_*$ , that is, that the epimorphism

$$\pi^*L^\alpha(F^\vee) \otimes_{\mathcal{O}_{\mathbb{G}}} \mathrm{Sym}_{\mathbb{G}}(G \otimes Q) \longrightarrow L^\alpha Q \otimes_{\mathcal{O}_{\mathbb{G}}} \mathrm{Sym}_{\mathbb{G}}(G \otimes Q)$$

remains an epimorphism upon applying  $\Gamma(\mathbb{G}, -)$ . In fact, it suffices to show that

$$\pi^*(L^\alpha(F^\vee) \otimes_{\mathcal{O}_{\mathbb{G}}} \mathrm{Sym}_{\mathbb{G}}(G \otimes F^\vee)) \longrightarrow L^\alpha Q \otimes_{\mathcal{O}_{\mathbb{G}}} \mathrm{Sym}_{\mathbb{G}}(G \otimes Q)$$

remains an epimorphism upon applying  $\Gamma(\mathbb{G}, -)$ . By Theorem 2.3, source and target are filtered by Schur functors, so it is enough to show that for any partition  $\delta$  the canonical map

$$\pi^*L^\delta(F^\vee) \longrightarrow L^\delta Q$$

remains an epimorphism upon applying  $\Gamma(\mathbb{G}, -)$ . But taking global sections of this map gives

$$L^\delta(F^\vee) \longrightarrow \Gamma(\mathbb{G}, L^\delta Q),$$

which is even an isomorphism by the definition of Schur modules. Hence, we are done. ■

Set  $\bar{T}_\alpha = \Gamma(Z, \mathcal{T}_\alpha)$ , where  $\mathcal{T}_\alpha = p'^*(\wedge^{\alpha'} Q)$  as in Theorem 2.1, and recall

$$T_\alpha = \mathrm{image} \left( \wedge^{\alpha'}(F^\vee) \otimes R \xrightarrow{(\wedge^{\alpha'} \psi^\vee) \otimes R} \wedge^{\alpha'}(G^\vee) \otimes R \right).$$

Filtering everything by Schur functors and applying Proposition 3.5, we see that these coincide.

**Corollary 3.6.** We have  $T_\alpha \cong \bar{T}_\alpha$  for each  $\alpha \in B_{l,m-l}$ . In particular,  $T \cong \bar{T}$  is a maximal Cohen–Macaulay  $R$ -module. □

Assembling the pieces, we obtain Theorem C and, as a consequence, Theorem A.

**Remark 3.7.** It follows from Proposition 3.5 that  $N_\alpha = M(\alpha, 0)$  in the notation of [24, Section 6]. In particular, the very general result [24, Corollary (6.5.17)] gives an alternative way to see that  $N_\alpha$  is Cohen–Macaulay in characteristic zero. Furthermore, [24, Example (6.5.18)] shows that  $N_2$  is not Cohen–Macaulay in characteristic 2.  $\square$

**Example 3.8.** Assume that  $m - l = 1$  with  $m \leq n$ . Then we have  $\mathbb{G} = \mathbb{P}^{m-1}$ . Set  $\mathbb{P} = \mathbb{P}^{m-1}$ , so that  $\mathcal{Q} = \Omega_{\mathbb{P}}^\vee(-1)$ , and let  $\alpha = 1^a$  for some  $a$ ,  $0 \leq a \leq m - 1$ . We find

$$\begin{aligned} \mathcal{T}_\alpha &= p'^*(\bigwedge^a \Omega_{\mathbb{P}}^\vee(-a)) \\ &= p'^*(\bigwedge^{m-1-a} \Omega_{\mathbb{P}} \otimes_{\mathcal{O}_{\mathbb{P}}} \omega_{\mathbb{P}}^{-1}(-a)) \\ &= p'^*(\bigwedge^{m-1-a} \Omega_{\mathbb{P}}(m-a)). \end{aligned}$$

Thus, in the notation of [5] we have  $T_\alpha = M_{m-a} = \text{cok } \bigwedge^{m-a} X$ .  $\square$

#### 4 Proof of Theorem D

We now need to refer to the two resolutions of  $\text{Spec } R$  in a uniform way, so we introduce appropriate symmetrical notation for this section only. We start by putting  $G_1 = F^\vee$  and  $G_2 = G$  so that

$$H = \text{Sym}_K(G_1 \otimes G_2).$$

We also put  $n_i = \text{rank}_K G_i$  and  $\mathbb{G}_i = \text{Grass}(n_i - l, G_i)$ . Thus,  $n_1 = m$ ,  $n_2 = n$ , and we have canonically  $\mathbb{G}_1 \cong \mathbb{G}$ .

For symmetry, we also put  $\mathcal{Z}_1 = \mathcal{Z}$ . In general, we will decorate the notations in the diagram (2) by a “1” or a “2” depending on whether they refer to  $\mathcal{Z}_1$  or  $\mathcal{Z}_2$ .

We now explain how we prove Theorem D. In Proposition 3.1, we have constructed tilting bundles  $\mathcal{T}_1, \mathcal{T}_2$  on  $\mathcal{Z}_1, \mathcal{Z}_2$ . For our purposes, it turns out to be technically more convenient to use the tilting bundle  $\mathcal{T}_1^\vee$  on  $\mathcal{Z}_1$  rather than  $\mathcal{T}_1$ . With  $E'_1, E_2$  the endomorphism rings of  $\mathcal{T}_1^\vee$  and  $\mathcal{T}_2$ , respectively, it turns out that if  $n_1 \leq n_2$ , then  $E'_1 \cong eE_2e$  for a suitable idempotent  $e \in E_2$ . Thus, we immediately obtain a fully faithful embedding  $D^b(\text{coh } \mathcal{Z}_1) \hookrightarrow D^b(\text{coh } \mathcal{Z}_2)$ . We then show that this embedding coincides with the indicated Fourier–Mukai transform.

Now we proceed with the actual proof. On  $\mathbb{G}_i$ , we have the tautological exact sequence

$$0 \longrightarrow \mathcal{R}_i \longrightarrow \pi_i^* G_i \longrightarrow \mathcal{Q}_i \longrightarrow 0.$$

We also define

$$\hat{Z} = Z_1 \times_H Z_2.$$

There are projection maps  $r_1: \hat{Z} \rightarrow Z_1, r_2: \hat{Z} \rightarrow Z_2$ . These fit together in the following commutative diagram.

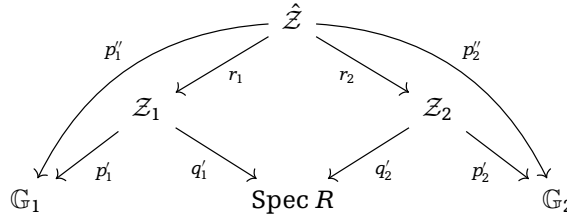

Let  $H_0 \subset \text{Spec } R$  be the (open) locus of tensors of rank exactly  $l$ , so that the maps  $q'_i$  and  $r_i$ , for  $i = 1, 2$ , are all isomorphisms above  $H_0$ . Let  $\hat{Z}_0$  be the inverse image of  $H_0$  in  $\hat{Z}$ .

Let  $\alpha$  be a partition and set  $\mathcal{T}_{\alpha,i} = p_i'^*(\wedge^{\alpha'} Q_i)$  for  $i = 1, 2$ . Further set  $B_i = B_{l,n_i-l}$ ,

$$\mathcal{T}_i = \bigoplus_{\alpha \in B_i} \mathcal{T}_{\alpha,i} \quad \text{and} \quad E_i = \text{End}_{\mathcal{O}_{Z_i}}(\mathcal{T}_i).$$

By Theorem C,  $\mathcal{T}_i$  is a tilting bundle on  $Z_i$  and hence  $\mathcal{D}^b(\text{coh } Z_i) \cong \mathcal{D}^b(\text{mod } E_i)$ .

Here is an asymmetrical piece of notation. Assume that  $n_1 \leq n_2$ . Then  $B_1 \subseteq B_2$ . Set

$$\mathcal{T}'_2 = \bigoplus_{\alpha \in B_1} \mathcal{T}_{\alpha,2} \subseteq \bigoplus_{\alpha \in B_2} \mathcal{T}_{\alpha,2} = \mathcal{T}_2 \quad \text{and} \quad E'_2 = \text{End}_{\mathcal{O}_{Z_2}}(\mathcal{T}'_2). \tag{4.1}$$

As  $\mathcal{T}'_2$  is a direct summand of  $\mathcal{T}_2$ , we have  $E'_2 = eE_2e$  for a suitable idempotent  $e \in E_2$ . Hence, there is a fully faithful embedding

$$\tilde{e}: \mathcal{D}^b(\text{mod } E'_2) \hookrightarrow \mathcal{D}^b(\text{mod } E_2) \tag{4.2}$$

given by  $\tilde{e}(\mathcal{M}) = (E_2)e \otimes_{E'_2} \mathcal{M}$ .

Put  $E'_1 = \text{End}_{\mathcal{O}_{Z_1}}(\mathcal{T}_1^\vee)$ . Note that it follows easily from Grothendieck duality that  $\mathcal{T}_1^\vee$  is also a tilting bundle on  $Z_1$ .

Finally, set

$$T_{\alpha,i} = q'_{i*} \mathcal{T}_{\alpha,i}, \quad T_i = q'_{i*} \mathcal{T}_i,$$

and  $T'_2 = q'_{2*} \mathcal{T}'_2$ . By Theorem C, we have  $E_i = \text{End}_R(T_i)$ ,  $E'_1 = \text{End}_R(T_1^\vee)$ , and  $E'_2 = \text{End}_R(T'_2)$ .

**Lemma 4.1.** One has  $\hat{Z} = \underline{\text{Spec}} (\text{Sym}_{\mathbb{G}_1 \times \mathbb{G}_2} (Q_1 \boxtimes Q_2))$ . □

**Proof.** This is a straightforward computation.

$$\begin{aligned}
 \mathcal{Z}_1 \times_H \mathcal{Z}_2 &= \mathcal{Z}_1 \times_{\mathbb{G}_1 \times H} (\mathbb{G}_1 \times H) \times_H (\mathbb{G}_2 \times H) \times_{\mathbb{G}_2 \times H} \mathcal{Z}_2 \\
 &= \mathcal{Z}_1 \times_{\mathbb{G}_1 \times H} (\mathbb{G}_1 \times \mathbb{G}_2 \times H) \times_{\mathbb{G}_2 \times H} \mathcal{Z}_2 \\
 &= (\mathcal{Z}_1 \times \mathbb{G}_2) \times_{\hat{\mathbb{G}} \times H} (\mathcal{Z}_2 \times \mathbb{G}_1) \\
 &= \underline{\text{Spec}} (\text{Sym}_{\mathbb{G}_1 \times \mathbb{G}_2} (\mathcal{Q}_1 \boxtimes \pi_2^* \mathcal{G}_2) \otimes_{\text{Sym}_{\mathbb{G}_1 \times \mathbb{G}_2} (\pi_1^* \mathcal{G}_1 \boxtimes \pi_2^* \mathcal{G}_2)} \text{Sym}_{\mathbb{G}_1 \times \mathbb{G}_2} (\pi_1^* \mathcal{G}_1 \boxtimes \mathcal{Q}_2)) \\
 &= \underline{\text{Spec}} (\text{Sym}_{\mathbb{G}_1 \times \mathbb{G}_2} (\mathcal{Q}_1 \boxtimes \mathcal{Q}_2)). \quad \blacksquare
 \end{aligned}$$

**Proposition 4.2.** Assume  $n_1 \leq n_2$ . Then  $T'_2 \cong T_1^\vee$ . In particular,  $E'_2 \cong E'_1$ , and there is a fully faithful embedding  $\mathcal{D}^b(\text{mod } E'_1) \hookrightarrow \mathcal{D}^b(\text{mod } E_2)$  (using (4.2)). If  $n_1 = n_2$ , then the embedding is an equivalence.  $\square$

**Proof.** Since  $\hat{\mathcal{Z}} = \underline{\text{Spec}} (\text{Sym}_{\mathbb{G}_1 \times \mathbb{G}_2} (\mathcal{Q}_1 \boxtimes \mathcal{Q}_2))$ , we have a canonical map

$$u: (p_2'')^* \mathcal{Q}_2 \longrightarrow (p_1'')^* \mathcal{Q}_1^\vee,$$

which is an isomorphism on  $\hat{\mathcal{Z}}_0$ . Apply  $\bigwedge^{\alpha'}(-)$  for a partition  $\alpha$  to obtain a map

$$\bigwedge^{\alpha'} u: r_2^* \mathcal{T}_{\alpha,2} \longrightarrow r_1^* (\mathcal{T}_{\alpha,1})^\vee \tag{4.3}$$

and push down with  $(q_1' r_1)_* = (q_2' r_2)_*$  to get a homomorphism of  $R$ -modules

$$\tau_\alpha: T_{\alpha,2} \longrightarrow T_{\alpha,1}^\vee, \tag{4.4}$$

which is an isomorphism on  $H_0$ . Letting  $\alpha$  run over partitions in  $B_1$ , we find a homomorphism  $\tau: T'_2 \longrightarrow T_1^\vee$  which is also an isomorphism on  $H_0$ . Since the exceptional loci for the  $q'_i$  in  $\mathcal{Z}_i$  have codimension at least 2, the modules  $T_1$  and  $T'_2$  are reflexive by [23, Lemma 4.2.1]. (In fact, we know already that  $T_1$  is Cohen–Macaulay.) Hence,  $\tau: T'_2 \longrightarrow T_1^\vee$  is an isomorphism.

In particular,  $\tau$  induces an isomorphism  $\tilde{\tau}: E'_1 \longrightarrow E'_2$ .  $\blacksquare$

The birational map  $\mathcal{Z}_2 \longrightarrow \mathcal{Z}_1$  is easily seen to be a *flip*, and, if  $n_1 = n_2$ , even a *flop*. Our final result thus verifies, in this special case, a general conjecture of Bondal and Orlov [4].

**Theorem 4.3.** Assume  $n_1 \leq n_2$ . Then there is a fully faithful embedding

$$\mathcal{F}: \mathcal{D}^b(\text{coh } \mathcal{Z}_1) \longrightarrow \mathcal{D}^b(\text{coh } \mathcal{Z}_2)$$

given by

$$\mathcal{F}(\mathcal{M}) = \mathcal{T}'_2 \overset{\mathbf{L}}{\otimes}_{E'_1} \mathbf{RHom}_{\mathcal{O}_{\mathcal{Z}_1}}(\mathcal{T}'_1^\vee, \mathcal{M}),$$

where  $E'_1 = \text{End}_R(\mathcal{T}'_1^\vee)$  acts on  $\mathcal{T}'_2$  via the isomorphism  $E'_1 \cong \text{End}_{\mathcal{O}_{\mathcal{Z}_2}}(\mathcal{T}'_2)$  of Proposition 4.2. If  $n_1 = n_2$ , then  $\mathcal{F}$  is an equivalence. □

**Proof.** Since  $\mathcal{T}'_1$  and  $\mathcal{T}_2$  are tilting on  $\mathcal{Z}_1$  and  $\mathcal{Z}_2$ , respectively, we have equivalences

$$\mathbf{RHom}_{\mathcal{O}_{\mathcal{Z}_1}}(\mathcal{T}'_1^\vee, -): \mathcal{D}^b(\text{coh } \mathcal{Z}_1) \longrightarrow \mathcal{D}^b(\text{mod} E'_1)$$

and

$$\mathcal{T}_2 \overset{\mathbf{L}}{\otimes}_{E_2} -: \mathcal{D}^b(\text{mod} E_2) \longrightarrow \mathcal{D}^b(\text{coh } \mathcal{Z}_2).$$

Putting these together with the isomorphism  $E'_1 \cong E'_2$  and the fully faithful embedding  $\bar{e}: \mathcal{D}^b(\text{mod} E'_2) \longrightarrow \mathcal{D}^b(\text{mod} E_2)$ , we find the composition

$$\mathcal{F}: \mathcal{D}^b(\text{coh } \mathcal{Z}_1) \xrightarrow{\cong} \mathcal{D}^b(\text{mod} E'_1) \xrightarrow{\cong} \mathcal{D}^b(\text{mod} E'_2) \hookrightarrow \mathcal{D}^b(\text{mod} E_2) \xrightarrow{\cong} \mathcal{D}^b(\text{coh } \mathcal{Z}_2),$$

of the form asserted. ■

**Theorem 4.4.** Assume that  $n_1 \leq n_2$ . Then the Fourier–Mukai transform  $\text{FM} = \mathbf{R}r_{2*} \mathbf{L}r_1^*$  with kernel  $(r_1, r_2)_* \mathcal{O}_{\hat{\mathcal{Z}}}$  defines a fully faithful embedding

$$\text{FM}: \mathcal{D}^b(\text{coh } \mathcal{Z}_1) \hookrightarrow \mathcal{D}^b(\text{coh } \mathcal{Z}_2),$$

which is an equivalence if  $n_1 = n_2$ . There is a natural isomorphism between FM and the functor  $\mathcal{F} = \mathcal{T}'_2 \overset{\mathbf{L}}{\otimes}_{E'_1} \mathbf{RHom}_{\mathcal{O}_{\mathcal{Z}_1}}(\mathcal{T}'_1^\vee, -)$  introduced in Proposition 4.3. In particular, FM is fully faithful. □

**Proof.** For a partition  $\alpha \in B_1$ , the map  $\bigwedge^{\alpha'} u: r_2^* \mathcal{T}_{\alpha,2} \longrightarrow r_1^*(\mathcal{T}_{\alpha,1})^\vee$  constructed in (4.3) gives by adjointness a homomorphism on  $\mathcal{Z}_2$

$$\sigma: \mathcal{T}_{\alpha,2} \longrightarrow \mathbf{R}r_{2*} r_1^*(\mathcal{T}_{\alpha,1})^\vee.$$

We claim that  $\sigma$  is an isomorphism. In particular, we must show  $\mathbf{R}^i r_{2*} r_1^*(\mathcal{T}_{\alpha,1})^\vee = 0$  for  $i > 0$ . To this latter end, it is sufficient to show that for all  $y \in \mathbb{G}_2$  and all  $i > 0$

we have

$$H^i(\mathbb{G}_1, \bigwedge^{\alpha'} \mathcal{Q}_1^\vee \otimes_{\mathcal{O}_{\mathbb{G}_1}} \text{Sym}_{\mathbb{G}_1}(\mathcal{Q}_1 \otimes (\mathcal{Q}_2)_Y)) = 0.$$

This follows again from the Cauchy formula together with Proposition 2.2.

Now we can see that  $\sigma: \mathcal{T}_{\alpha,2} \rightarrow r_{2*}r_1^*(\mathcal{T}_{\alpha,1})^\vee$  is an isomorphism. The source is reflexive, the target is torsion-free, and over  $\hat{Z}_0$  the map  $\sigma$  coincides with  $(q_2')^*\tau_\alpha$ , where  $\tau_\alpha: \mathcal{T}_{\alpha,2} \rightarrow \mathcal{T}_{\alpha,1}^\vee$  as in (4.4). Since each  $\tau_\alpha$  is an isomorphism, so is  $\sigma$ .

In particular, we obtain an isomorphism  $\tilde{\sigma}: \mathcal{T}'_2 \rightarrow \mathbf{R}r_{2*}\mathbf{L}r_1^*\mathcal{T}_1^\vee$  by summing over  $\alpha \in B_1$ .

To define the desired natural transformation  $\eta: \mathcal{F} \rightarrow \text{FM}$ , we must construct a morphism

$$\eta(\mathcal{M}): \mathcal{T}'_2 \otimes_{E'_1}^{\mathbf{L}} \mathbf{R}\text{Hom}_{\mathcal{O}_{Z_1}}(\mathcal{T}_1^\vee, \mathcal{M}) \rightarrow \mathbf{R}r_{2*}\mathbf{L}r_1^*\mathcal{M}$$

for every  $\mathcal{M}$  in  $\mathcal{D}^b(\text{coh } Z_1)$ . The desired map is the composition of

$$\begin{array}{c} \mathcal{T}'_2 \otimes_{E'_1}^{\mathbf{L}} \mathbf{R}\text{Hom}_{\mathcal{O}_{Z_1}}(\mathcal{T}_1^\vee, \mathcal{M}) \\ \downarrow \tilde{\sigma} \otimes_{E'_1} \mathbf{R}r_{2*}\mathbf{L}r_1^* \\ \mathbf{R}r_{2*}\mathbf{L}r_1^*\mathcal{T}_1^\vee \otimes_{E'_1}^{\mathbf{L}} \mathbf{R}\text{Hom}_{\mathcal{O}_{Z_2}}(\mathbf{R}r_{2*}\mathbf{L}r_1^*\mathcal{T}_1^\vee, \mathbf{R}r_{2*}\mathbf{L}r_1^*\mathcal{M}) \end{array}$$

and the evaluation map from the derived tensor product to  $\mathbf{R}r_{2*}\mathbf{L}r_1^*\mathcal{M}$ . To show that  $\eta$  is an isomorphism, it suffices, since  $\mathcal{T}_1^\vee$  generates, to prove that  $\eta(\mathcal{T}_1^\vee)$  is an isomorphism.

In this case, we have

$$\mathcal{T}'_2 \otimes_{E'_1}^{\mathbf{L}} \mathbf{R}\text{Hom}_{\mathcal{O}_{Z_1}}(\mathcal{T}_1^\vee, \mathcal{T}_1^\vee) \cong \mathcal{T}'_2 \otimes_{E'_1}^{\mathbf{L}} E'_1 \cong \mathcal{T}'_2 \cong \mathbf{R}r_{2*}\mathbf{L}r_1^*\mathcal{T}_1^\vee,$$

an isomorphism by construction. ■

**Remark 4.5.** Though we did not use it, in fact we have  $E'_1 \cong E_1$ . Indeed, for  $\alpha = (\alpha_1, \dots, \alpha_l) \in B_i$ , define

$$\alpha^l = (n_i - l - \alpha_l, \dots, n_i - l - \alpha_1).$$

Then

$$\bigwedge^{\alpha'} \mathcal{Q}_i^\vee \cong (\bigwedge^l \mathcal{Q}_i)^{-(n_i-l)} \otimes_{\mathcal{O}_{\mathbb{G}_i}} \bigwedge^{(\alpha^l)'} \mathcal{Q}_i.$$

Thus,

$$(\mathcal{T}_{\alpha,i})^\vee \cong p_i^*(\bigwedge^l \mathcal{Q}_i)^{-(n_i-l)} \otimes_{\mathcal{O}_{Z_i}} \mathcal{T}_{\alpha^l,i}$$



and hence

$$\mathcal{T}_i^\vee \cong p_i^*(\wedge^l \mathcal{Q})^{-(n_i-l)} \otimes_{\mathcal{O}_{\mathcal{Z}_i}} \mathcal{T}_i.$$

It follows that  $\text{End}_{\mathcal{O}_{\mathcal{Z}_i}}(\mathcal{T}_i^\vee) \cong \text{End}_{\mathcal{O}_{\mathcal{Z}_i}}(\mathcal{T}_i)$ . □

### 5 Presentations of the Simples

Throughout this section, we assume that the characteristic of our ground field is zero. We give an algorithm, based on Bott’s theorem and the Littlewood–Richardson rule, for determining the Ext-groups between the simple modules over the non-commutative desingularization. We work out explicitly the representations appearing in the Ext-groups of low degree, for later use in the proof of Theorem B. The method is a direct generalization of that used in [5] for the case of maximal minors, and was independently established in a more general form by Weyman and Zhao [25]. It was known to the authors how to extend our methods to arbitrary minors, but after seeing [25] we realized we could simplify the part of the argument involving Bott’s theorem. In particular, Lemma 5.4 is contained in [25, Corollary 3.6]. We provide a proof for the convenience of the reader.

Since we work in characteristic zero, we consider the tilting bundle  $\mathcal{N} = \bigoplus_\alpha \mathcal{N}_\alpha = \bigoplus_\alpha p^* L^\alpha \mathcal{Q}$  (cf. Proposition 3.5) on the desingularization  $\mathcal{Z}$  and its endomorphism ring  $A = \text{End}_{\mathcal{O}_{\mathcal{Z}}}(\mathcal{N})$ . Then  $A$  is Morita equivalent to  $E = \text{End}_R(T)$  of Theorem A.

For  $\alpha \in B_{l,m-l}$ , let  $P_\alpha = \text{Hom}_{\mathcal{O}_{\mathcal{Z}}}(\mathcal{N}, \mathcal{N}_\alpha)$  be the projective left  $A$ -module corresponding to  $\alpha$ , and let  $S_\alpha$  be its associated simple module. As in [5], we have the following identification of  $S_\alpha$ .

**Lemma 5.1.** Let  $u: \mathbb{G} \rightarrow \mathcal{Z}$  be the zero section of the vector bundle  $p': \mathcal{Z} \rightarrow \mathbb{G}$ . Then the object in  $\mathcal{D}^b(\text{coh } \mathcal{Z})$  corresponding to the simple module  $S_\alpha$  is  $u_* L^{\alpha'} \mathcal{R}[|\alpha|]$ . □

**Proof.** By [15], the bundles  $\{L^{\alpha'} \mathcal{R}[|\alpha|]\}_{\alpha \in B_{l,m-l}}$  form a dual exceptional collection to the full strong exceptional collection  $\{L^\alpha \mathcal{Q}\}_{\alpha \in B_{l,m-l}}$ , that is,

$$\text{Ext}_{\mathcal{O}_{\mathbb{G}}}^t(L^\alpha \mathcal{Q}, L^{\beta'} \mathcal{R}[|\beta|]) = \begin{cases} K & \text{if } t=0 \text{ and } \alpha = \beta \text{ and} \\ 0 & \text{otherwise.} \end{cases}$$

This Ext group is by adjunction isomorphic to  $\text{Ext}_{\mathcal{O}_{\mathcal{Z}}}^t(p^* L^\alpha \mathcal{Q}, u_* L^{\beta'} \mathcal{R}[|\beta|])$ . Since  $p^* L^\alpha \mathcal{Q}$  corresponds to the projective  $P_\alpha$  over  $A$ , this gives the desired statement. ■

To compute the extensions between the simple objects, we use the following proposition [5, Proposition 10.6]. The proof given in [5] is over  $\mathbb{P}$ , but is equally valid over  $\mathbb{G}$ .

**Lemma 5.2.** Let  $\mathcal{U}, \mathcal{V}$  be objects in  $\mathcal{D}^b(\text{coh } \mathbb{G})$ . Then

$$\text{Ext}_{\mathcal{O}_{\mathbb{Z}}}^t(u_*\mathcal{U}, u_*\mathcal{V}) = \bigoplus_s \text{Ext}_{\mathcal{O}_{\mathbb{G}}}^{t-s}(\wedge^s(\mathcal{Q} \otimes G) \otimes_{\mathcal{O}_{\mathbb{G}}} \mathcal{U}, \mathcal{V}). \quad \square$$

**Theorem 5.3.** Let  $\alpha, \beta \in B_{l,m-l}$ . For the simple left  $A$ -modules  $S_\alpha$  and  $S_\beta$ , we have

$$\text{Ext}_A^t(S_\beta, S_\alpha) = \bigoplus_\lambda H^{t-|\lambda|+|\alpha|-|\beta|}(\mathbb{G}, L^\lambda \mathcal{Q}^\vee \otimes L^{\alpha'} \mathcal{R} \otimes L^{\beta'} \mathcal{R}^\vee) \otimes L^{\lambda'} G^\vee,$$

where the sum is over all  $\lambda \in B_{l,n}$ . □

Observe that the  $\lambda$  appearing in the formula have the same bound on the number of rows as  $\alpha$  and  $\beta$ , but the constraint on their widths depends on  $G$ .

**Proof.** This is a direct calculation using Lemma 5.2 and the Cauchy decomposition from Proposition 2.3:

$$\begin{aligned} \text{Ext}_A^t(S_\beta, S_\alpha) &= \text{Ext}_{\mathcal{O}_{\mathbb{Z}}}^t(u_*L^{\beta'} \mathcal{R}[|\beta|], u_*L^{\alpha'} \mathcal{R}[|\alpha|]) \\ &= \text{Ext}_{\mathcal{O}_{\mathbb{Z}}}^{t+|\alpha|-|\beta|}(u_*L^{\beta'} \mathcal{R}, u_*L^{\alpha'} \mathcal{R}) \\ &= \bigoplus_s \text{Ext}_{\mathcal{O}_{\mathbb{G}}}^{t-s+|\alpha|-|\beta|}(\wedge^s(\mathcal{Q} \otimes G) \otimes_{\mathcal{O}_{\mathbb{G}}} L^{\beta'} \mathcal{R}, L^{\alpha'} \mathcal{R}) \\ &= \bigoplus_s H^{t-s+|\alpha|-|\beta|}(\mathbb{G}, \wedge^s(\mathcal{Q} \otimes G)^\vee \otimes_{\mathcal{O}_{\mathbb{G}}} (L^{\beta'} \mathcal{R})^\vee \otimes L^{\alpha'} \mathcal{R}) \\ &= \bigoplus_s \bigoplus_{|\lambda|=s} H^{t-s+|\alpha|-|\beta|}(\mathbb{G}, L^\lambda \mathcal{Q}^\vee \otimes_{\mathcal{O}_{\mathbb{G}}} L^{\alpha'} \mathcal{R} \otimes L^{\beta'} \mathcal{R}^\vee) \otimes L^{\lambda'} G^\vee, \end{aligned}$$

which is equal to the desired sum since  $\text{rank } \mathcal{Q} = l$  and  $\text{rank } G = n$ . ■

For any given  $t$ , computing the cohomology indicated in the theorem is algorithmic, though a complete combinatorial description of exactly which representations appear remains open. We can evaluate the sum for small values of  $t$  using the Littlewood–Richardson rule and Bott’s theorem [24]. Recall the algorithm of Bott: a bundle of the form  $L^\lambda \mathcal{Q}^\vee \otimes L^\gamma \mathcal{R}^\vee$ , for dominant weights  $\lambda$  and  $\gamma$ , has at most one non-vanishing cohomology group, and the index  $k$  for which  $H^k(\mathbb{G}, L^\lambda \mathcal{Q}^\vee \otimes L^\gamma \mathcal{R}^\vee) \neq 0$  is computed by flattening the weight  $(\gamma, \delta)$  using the twisted action of the symmetric group

$S_m$ . (Technically, we must flatten  $(\lambda^*, \gamma^*)$ , where  $\lambda^* = -w_0\lambda$  and  $w_0$  is the long word in  $S_m$ . However, it is easy to see that the result is the same, since passing to the dual Grassmannian replaces  $(\lambda^*, \gamma^*)$  with  $(\gamma, \lambda)$ .) This means that the adjacent transpositions  $\sigma_i = (i, i + 1)$  act on a weight  $\alpha = (\alpha_1, \dots, \alpha_m)$  by  $\sigma_i \cdot \alpha = (\alpha_1, \dots, \alpha_{i+1} + 1, \alpha_i - 1, \dots, \alpha_m)$ . If there exists a permutation  $\tau$  such that  $\tau \cdot (\gamma, \lambda)$  is dominant (i.e., weakly decreasing), then the only non-vanishing cohomology is

$$H^{l(\tau)}(\mathbb{G}, L^\lambda Q^\vee \otimes L^\gamma \mathcal{R}^\vee) = L^{\tau \cdot (\gamma, \lambda)} F,$$

where  $l(\tau)$  is the length of  $\tau$ 's expansion in adjacent transpositions. If there exists no such  $\tau$ , or equivalently  $\tau \cdot (\gamma, \lambda) = (\gamma, \lambda)$  for some non-trivial  $\tau \in S_m$ , then all cohomology of  $L^\lambda Q^\vee \otimes L^\gamma \mathcal{R}^\vee$  vanishes.

We can describe the algorithm equivalently by defining the action of  $S_m$  via  $\sigma_i \cdot \alpha = \sigma_i(\alpha + \rho) - \rho$ , where  $\rho = (m - 1, m - 2, \dots, 1, 0)$ . If  $\alpha + \rho$  contains a repetition, there is no cohomology.

Note that in this procedure  $\gamma$  and  $\lambda$  are not assumed to have non-negative entries. We write  $\alpha = \alpha_+ + \alpha_-$  for the decomposition of a weight  $\alpha$  into positive and negative parts, and  $|\alpha| = |\alpha_+| + |\alpha_-|$  for the signed area of  $\alpha$ .

We need a combinatorial lemma. (A similar argument in [25] allowed us to simplify our original argument significantly.) The  $L^\gamma \mathcal{R}^\vee$  appearing in the Littlewood–Richardson decomposition of  $L^{\alpha'} \mathcal{R} \otimes L^{\beta'} \mathcal{R}^\vee$ , for  $\alpha, \beta \in B_{l, m-l}$ , will have  $\gamma_i \geq -l$  for all  $i$ .

**Lemma 5.4.** Let  $\gamma = (\gamma_1, \dots, \gamma_{m-l})$  and  $\lambda = (\lambda_1, \dots, \lambda_l)$  be dominant weights. Assume that  $\gamma_i \geq -l$  for all  $i$ . If  $H^k(\mathbb{G}, L^\lambda Q^\vee \otimes L^\gamma \mathcal{R}^\vee) \neq 0$  for some  $k$ , then  $-\gamma_- \subseteq \lambda'$  and  $k \geq -|\gamma_-|$ . In particular, if  $H^{t-|\lambda|+|\gamma|}(\mathbb{G}, L^\lambda Q^\vee \otimes L^\gamma \mathcal{R}^\vee) \neq 0$  for some  $t$ , then  $t - |\lambda| \geq |\gamma_+|$ .  $\square$

**Proof.** We have to show that the negative part of  $\gamma$  is contained in the first columns of  $\lambda$ . If  $\gamma$  has no negative entries, we are of course done. Set  $s = -\gamma_{m-l} \leq l$  and assume  $s > 0$ . Then  $\lambda$  can have at most  $l - s$  zero entries, for otherwise  $(\gamma, \lambda) + \rho = (\gamma_1 + m - 1, \dots, \gamma_{m-l-1} + l + 1, l - s, \lambda_1 + l - 1, \dots, \lambda_l)$  would have a repetition of  $l - s$  and all cohomology would vanish. The result of partially flattening  $\gamma_{m-l}$  is therefore  $(\gamma_1, \dots, \gamma_{m-l-1}, \lambda_1 - 1, \dots, \lambda_s - 1, 0, \lambda_{s-1}, \dots, \lambda_l)$  and  $\lambda_s - 1 \geq 0$ . Since  $\gamma_{m-l-1} \geq -s$ , we may repeat the argument with the weight  $(\gamma_1, \dots, \gamma_{m-l-1}, \lambda_1 - 1, \dots, \lambda_s - 1)$  to see that  $(\lambda_1 - 1, \dots, \lambda_s - 1)$  can have at most  $s - \gamma_{m-l-1}$  zero entries. Iterate. The last sentence is clear from  $|\gamma| = |\gamma_+| + |\gamma_-|$ .  $\blacksquare$

Recall that we use the notation  $\alpha \nearrow \beta$  to indicate that  $\beta$  is obtained from  $\alpha$  by adding a single box.

5.1 Computation of  $\text{Ext}^t$  for  $t=0, 1, 2$ 

We apply Bott's algorithm first with  $t=0$  to compute  $\text{Hom}_A(S_\beta, S_\alpha)$  as a sanity check. Theorem 5.3 asks us to compute

$$\bigoplus_{\lambda \in B_{l,n}} H^{-|\lambda|+|\gamma|}(\mathbb{G}, L^\lambda \mathcal{Q}^\vee \otimes L^\gamma \mathcal{R}^\vee) \otimes L^{\lambda'} G^\vee$$

for all  $\gamma$  such that  $L^\gamma \mathcal{R}^\vee$  appears in  $L^{\alpha'} \mathcal{R} \otimes L^{\beta'} \mathcal{R}^\vee$ . By the lemma, if this cohomology is non-zero, then we must have  $-|\lambda| \geq |\gamma_+|$ , which since  $\lambda$  is non-negative forces  $\lambda = (0, \dots, 0)$  and  $\gamma_+ = (0, \dots, 0)$ . The lemma furthermore implies  $-\gamma_- \subseteq \lambda'$ , so  $\gamma$  is also the zero partition. This occurs only when  $\alpha = \beta$ , and we obtain

$$\text{Hom}_A(S_\beta, S_\alpha) = \begin{cases} K & \text{if } \alpha = \beta \text{ and} \\ 0 & \text{otherwise,} \end{cases}$$

as expected.

For  $t=1$ ,  $1 - |\lambda| \geq |\gamma_+|$  implies either  $\lambda = (0, \dots, 0)$  or  $\lambda = (1, \dots, 0)$ . In the first case, we find  $\gamma_- = 0$  and  $\gamma_+$  can be either  $(0, \dots, 0)$  or  $(1, \dots, 0)$ . The first choice for  $\gamma$  leads to  $H^1(\mathbb{G}, \mathcal{O}_{\mathbb{G}}) = 0$ , and the second to  $H^0(\mathbb{G}, \mathcal{R}^\vee) = F$ . In the second case, we have  $\gamma_+ = 0$  and  $\gamma_- = (0, \dots, 0)$  or  $(0, \dots, -1)$  since  $-\gamma_- \subseteq \lambda'$ . Here the first choice gives no cohomology and the second contributes  $H^1(\mathbb{G}, \mathcal{Q}^\vee \otimes \mathcal{R}) = K$ .

A direct summand of the form  $L^{(1,0,\dots,0)} \mathcal{R}^\vee$  appearing in  $L^{\alpha'} \mathcal{R} \otimes L^{\beta'} \mathcal{R}^\vee$  implies that  $\alpha' \subseteq \beta'$  and  $\beta'$  differs from  $\alpha'$  in exactly one entry, where  $\beta'_i = \alpha'_i + 1$ , so  $\alpha \nearrow \beta$ . Similarly, the appearance of  $L^{(0,\dots,0,-1)} \mathcal{R}^\vee$  indicates that  $\beta$  is the result of removing a box from  $\alpha$ . Thus,

$$\text{Ext}_A^1(S_\beta, S_\alpha) = \begin{cases} F & \text{if } \alpha \nearrow \beta, \\ G^\vee & \text{if } \beta \nearrow \alpha, \text{ and} \\ 0 & \text{otherwise.} \end{cases}$$

The case  $t=2$  requires considering several cases corresponding to  $|\lambda|=0, 1, 2$ . If  $\lambda$  is the zero partition, then  $\gamma_- = 0$  and  $\gamma_+$  is one of  $(0, \dots, 0)$ ,  $(1, \dots, 0)$ ,  $(2, \dots, 0)$  or  $(1, 1, 0, \dots, 0)$ . These are all already dominant, so contribute only  $H^0$ , so we obtain  $H^0(\mathbb{G}, \text{Sym}_2 \mathcal{R}^\vee) = \text{Sym}_2 F$  and  $H^0(\mathbb{G}, \wedge^2 \mathcal{R}^\vee) = \wedge^2 F$ . These  $\gamma$  correspond to obtaining  $\beta'$  by adding to  $\alpha'$ , respectively, two boxes not in the same column and two boxes not in the same row.

In case  $\lambda = (1, 0, \dots, 0)$  then  $|\gamma_+| \leq 1$  and  $-|\gamma_-| \leq 1$ . The case  $\gamma = (0, \dots, 0)$  gives no cohomology. If  $\gamma = (0, \dots, 0, -1)$ , then one swap gives the zero partition so we find

a contribution to  $H^1$  but none to  $H^2$ . If  $\gamma = (1, 0, \dots, 0, -1)$ , then we obtain  $H^1(\mathbb{G}, \mathcal{Q}^\vee \otimes L^{(1,0,\dots,0,-1)}\mathcal{R}^\vee) = F$ . These  $\gamma$  correspond to the  $\beta'$  obtained by adding one box to  $\alpha'$  and removing one box. Finally, if  $\lambda = (1, 0, \dots, 0)$  and  $\gamma = (1, 0, \dots, 0)$ , then we again have no cohomology, unless  $\gamma$  has just one entry, in which case  $m - l = 1$  and we get  $H^0(\mathbb{G}, \mathcal{Q}^\vee \otimes \mathcal{R}^\vee) = L^{(1,1,0,\dots,0)}F = \bigwedge^2 F$ . This arises from  $\alpha' \nearrow \beta'$ .

Assume  $\lambda = (1, 1, 0, \dots, 0)$ . Then  $\gamma_+ = 0$  and the possibilities for  $\gamma_-$  are  $(0, \dots, 0)$ ,  $(0, \dots, 0, -1)$ , and  $(0, \dots, 0, -2)$ . The first and second cases lead to no cohomology, while the third possibility takes two swaps to give the zero partition, so  $H^2(\mathbb{G}, \bigwedge^2 \mathcal{Q} \otimes L^{(0,\dots,0,-2)}\mathcal{R}^\vee) = K$ . This  $\gamma$  appears when  $\alpha'$  is obtained by adding two boxes to  $\beta'$ , not in the same row.

Lastly suppose  $\lambda = (2, 0, \dots, 0)$ . Then again  $\gamma_+ = 0$  and now the possibilities for  $\gamma_-$  are  $(0, \dots, 0)$ ,  $(0, \dots, 0, -1)$ , and  $(0, \dots, 0, -1, -1)$ . The first case gives no cohomology unless  $m - l = 1 = l$ , in which case  $(0, 2)$  flattens in one swap to  $(1, 1)$  and we get a contribution to  $H^1$  but none to  $H^0$ . The second case flattens in one step to  $(0, \dots, 0, 1, 0, \dots, 0)$ , which gives no cohomology if  $m - l > 1$  and  $H^1(\mathbb{G}, \text{Sym}_2 \mathcal{Q} \otimes L^{(0,\dots,0,-1)}\mathcal{R}^\vee) = F$  if  $m - l = 1$ . This occurs when  $\alpha' \nearrow \beta'$ . The third case flattens to the zero partition in two swaps, so gives  $H^2(\mathbb{G}, \text{Sym}_2 \mathcal{Q} \otimes L^{(0,\dots,0,-1,-1)}\mathcal{R}^\vee) = K$ . This occurs when  $\alpha'$  is obtained by adding two boxes to  $\beta'$ , not in the same column.

Analyzing the ways in which the  $L^\gamma \mathcal{R}^\vee$  appearing above can appear in  $L^{\alpha'} \mathcal{R} \otimes L^{\beta'} \mathcal{R}^\vee$ , we arrive at the final results. If  $m - l > 1$ , then  $\text{Ext}_A^2(S_\beta, S_\alpha)$  is given by

$$\left\{ \begin{array}{ll} \text{Sym}_2 F & \text{if } \alpha \nearrow \nearrow \beta, \text{ two boxes in a column,} \\ \bigwedge^2 F & \text{if } \alpha \nearrow \nearrow \beta, \text{ two boxes in a row,} \\ \text{Sym}_2 F \oplus \bigwedge^2 F \cong F \otimes F & \text{if } \alpha \nearrow \nearrow \beta, \text{ two disconnected boxes,} \\ F \otimes G^\vee & \text{if } \alpha \neq \beta \text{ and } \alpha \nearrow \delta, \beta \nearrow \delta, \text{ for some } \delta \in B_{l,m-l}, \\ (F \otimes G^\vee)^{\oplus t(\alpha)-1} & \text{if } \alpha = \beta, \\ \text{Sym}_2 G^\vee & \text{if } \beta \nearrow \nearrow \alpha, \text{ two boxes in a column,} \\ \bigwedge^2 G^\vee & \text{if } \beta \nearrow \nearrow \alpha, \text{ two boxes in a row,} \\ \text{Sym}_2 G^\vee \oplus \bigwedge^2 G^\vee \cong G^\vee \otimes G^\vee & \text{if } \beta \nearrow \nearrow \alpha, \text{ two disconnected boxes.} \end{array} \right. \quad (5.1)$$

Here  $t(\alpha)$  is the number of ways to add a box to  $\alpha$  without passing out of the sides of the box  $B_{l,m-l}$ . This is the case corresponding to  $\gamma = (1, 0, \dots, 0, -1)$  and  $\alpha = \beta$ .

In the case of maximal minors, where  $m - l = 1$ , some of the cases above do not occur and also we have some additional contributions to  $\text{Ext}^2$ . In that case

we find

$$\text{Ext}_A^2(S_\beta, S_\alpha) = \begin{cases} \text{Sym}_2 F & \text{if } \alpha \nearrow \nearrow \beta, \text{ two boxes in a column,} \\ \text{Sym}_2 G^\vee & \text{if } \beta \nearrow \nearrow \alpha, \text{ two boxes in a column,} \\ \wedge^2 F \otimes G^\vee & \text{if } \alpha \nearrow \beta, \\ F \otimes \wedge^2 G^\vee & \text{if } \beta \nearrow \alpha. \end{cases}$$

**Remark 5.5.** The computation of  $\text{Ext}^2(S_\beta, S_\alpha)$  when  $m - l = 1$  appears already in [5, Example 10.3], and the cubic relations between adjacent vertices in the last two lines above are reflected in the commutativity relations on the quiverized Clifford algebra in [5, Remark 7.6]. See Proposition A.10 for an explanation of their disappearance when  $m - l > 1$ . □

## 6 The Young Quiver with Pieri Relations

We continue to assume that  $K$  is a field of characteristic zero.

Now we give an explicit description of the non-commutative desingularization as a path algebra of a certain quiver with relations. The vertices of the quiver are identified with partitions  $\alpha \in B_{l, m-l}$ , or alternatively with the corresponding vector bundles  $\mathcal{N}_\alpha = p^* L^\alpha \mathcal{Q}$  on  $\mathcal{Z}$ , or again with the corresponding MCM  $R$ -modules  $N_\alpha$ . The arrows from  $\alpha$  to  $\beta$  will, in accordance with Example 5.1, correspond to (a basis of)  $F^\vee$  if  $\alpha \nearrow \beta$ , and to (a basis of)  $G$  if  $\beta \nearrow \alpha$ . To define an explicit action of the arrows on the modules or bundles, however, requires a bookkeeping device.

Fix a  $K$ -vector space  $V$  of dimension  $d$ . For irreducible (rational) representations  $L^\alpha V$  and  $L^\beta V$  of  $\text{GL}(V)$ , we know that the tensor product  $L^\alpha V \otimes L^\beta V$  has a canonical decomposition into irreducibles  $\bigoplus_\gamma (L^\gamma V)^{c_{\alpha\beta}^\gamma}$  with multiplicities  $c_{\alpha\beta}^\gamma$ , but in general the decomposition projectors are defined only up to some choices of bases for the vector spaces  $\text{Hom}_{\text{GL}(V)}(L^\alpha V \otimes L^\beta V, L^\gamma V)$ . To avoid making these choices, we introduce the following notation.

**Definition 6.1.** Let  $\alpha_1, \dots, \alpha_r$  and  $\beta_1, \dots, \beta_s$  be dominant weights for  $\text{GL}(V)$ , and set

$$\mathbb{L}_{\alpha_1 \dots \alpha_r}^{\beta_1 \dots \beta_s} = \text{Hom}_{\text{GL}(V)}(L^{\alpha_1} V \otimes \dots \otimes L^{\alpha_r} V, L^{\beta_1} V \otimes \dots \otimes L^{\beta_s} V). \quad \square$$

The spaces  $\mathbb{L}_{\alpha_1 \dots \alpha_r}^{\beta_1 \dots \beta_s}$  satisfy various easily verified properties. Denote by  $\alpha^*$  the dominant weight corresponding to the dual representation  $(L^\alpha V)^\vee = \text{Hom}_{\text{GL}(V)}(L^\alpha V, K)$ .

**Proposition 6.2.** Let  $\alpha_1, \dots, \alpha_r, \beta_1, \dots, \beta_s$  be dominant weights and let  $\sigma \in S_r$ . We have canonical (basis-independent) isomorphisms

- (i)  $\mathbb{L}_{\alpha_1 \dots \alpha_r}^{\beta_1 \dots \beta_s} = \mathbb{L}_{\alpha_{\sigma(1)} \dots \alpha_{\sigma(r)}}^{\beta_1 \dots \beta_s};$
- (ii)  $\mathbb{L}_{\alpha_1 \dots \alpha_r}^{\beta_1 \dots \beta_s} = \mathbb{L}_{\alpha_1 \dots \alpha_{r-1}}^{\beta_1 \dots \beta_s \alpha_r^*};$
- (iii)  $\mathbb{L}_{\alpha_1 \dots \alpha_r}^{\beta_1 \dots \beta_s} = \bigoplus_{\gamma} \mathbb{L}_{\gamma \alpha_{i+1} \dots \alpha_r}^{\beta_1 \dots \beta_s} \otimes \mathbb{L}_{\alpha_1 \dots \alpha_i}^{\gamma};$
- (iv)  $(\mathbb{L}_{\alpha_1 \dots \alpha_r}^{\beta_1 \dots \beta_s})^{\vee} = \mathbb{L}_{\beta_1 \dots \beta_s}^{\alpha_1 \dots \alpha_r}.$  □

The cases of (iv) we will use most often are the identifications

$$(\mathbb{L}_{1\alpha}^{\beta})^{\vee} = \mathbb{L}_{\beta}^{1\alpha} \quad \text{and} \quad (\mathbb{L}_{1^* \alpha}^{\beta})^{\vee} = \mathbb{L}_{\beta}^{1^* \alpha}.$$

Here

$$\mathbb{L}_{1\alpha}^{\beta} \cong \begin{cases} K & \text{if } \alpha \nearrow \beta \text{ and} \\ 0 & \text{otherwise;} \end{cases}$$

$$\mathbb{L}_{1^* \alpha}^{\beta} \cong \begin{cases} K & \text{if } \beta \nearrow \alpha \text{ and} \\ 0 & \text{otherwise.} \end{cases}$$

In particular, these properties yield a “categorified Pieri rule” yielding a canonical decomposition

$$V \otimes L^{\alpha} V \cong \bigoplus_{\beta} L^{\beta} V \otimes (\mathbb{L}_{1\alpha}^{\beta})^{\vee},$$

and similarly

$$V^{\vee} \otimes L^{\alpha} V \cong \bigoplus_{\beta} L^{\beta} V \otimes (\mathbb{L}_{1^* \alpha}^{\beta})^{\vee},$$

where the sum in each case is over *all* partitions  $\beta$ . More generally, we have a “categorified Littlewood–Richardson rule”

$$L^{\alpha} V \otimes L^{\beta} V = \bigoplus_{\gamma} L^{\gamma} V \otimes (\mathbb{L}_{\alpha\beta}^{\gamma})^{\vee}$$

and the dimensions of the spaces  $\mathbb{L}_{\alpha\beta}^{\gamma}$  are given by the usual Littlewood–Richardson numbers  $c_{\alpha\beta}^{\gamma}$ . There is no canonical choice of bases for the spaces  $\mathbb{L}_{\gamma}^{\alpha\beta}$ , but see Section 7.

Now we are ready to define the (truncated) Young quiver and its action on the tilting bundle. Return to the notation set in Section 1, so that  $F^{\vee}$  and  $G$  are  $K$ -vector spaces of ranks  $m$  and  $n$ , respectively, and  $l < \min\{m, n\}$ .

**Definition 6.3.** Let  $\mathbb{Y}$  be the quiver having vertices labeled by dominant weights  $\alpha$  for  $GL(l)$ , and arrows  $\alpha \rightarrow \beta$  indexed by

$$\begin{cases} \mathbb{L}_{1\alpha}^\beta \otimes F^\vee & \text{if } \alpha \nearrow \beta \text{ and} \\ \mathbb{L}_{1^*\alpha}^\beta \otimes G & \text{if } \beta \nearrow \alpha. \end{cases}$$

Further let  $\mathbb{Y}_{l,m-l}$  be the subquiver of  $\mathbb{Y}$  obtained by deleting all vertices  $\alpha$  having more than  $l$  rows or more than  $m - l$  columns, as well as all the arrows incident to them.  $\square$

To define a ring homomorphism from the path algebra  $K[\mathbb{Y}_{l,m-l}]$  to the non-commutative desingularization  $A = \text{End}_{\mathcal{O}_{\mathbb{Z}}}\mathcal{N}$ , we must define an action of the arrows on the summands  $\mathcal{N}_\alpha = p^*L^\alpha Q$ .

**Proposition 6.4.** There is a ring homomorphism  $K[\mathbb{Y}_{l,m-l}] \rightarrow \text{End}_{\mathcal{O}_{\mathbb{Z}}}(\mathcal{N})$ .  $\square$

**Proof.** As in the proof of Proposition 3.5, let  $\psi: q^*(G \otimes S) \rightarrow q^*(F \otimes S)$  be the pullback of the generic map of free  $S$ -modules to  $\mathcal{Z}$ , and let  $(V, \theta)$  be a point of  $\mathcal{Z}$ . The fiber of the dual  $\psi^\vee$  over  $(V, \theta)$  factors as

$$F^\vee \rightarrow V^\vee \rightarrow G^\vee$$

so we have induced maps of bundles

$$p^*\pi^*F^\vee \rightarrow p^*Q \rightarrow p^*\pi^*G^\vee.$$

Tensoring with  $\mathcal{N}_\alpha = p^*L^\alpha Q$  and an appropriate  $\mathbb{L}$ , we obtain natural maps

$$\begin{aligned} \mathbb{L}_{1\alpha}^\beta \otimes p^*\pi^*F^\vee \otimes p^*L^\alpha Q &\rightarrow \mathbb{L}_{1\alpha}^\beta \otimes p^*Q \otimes p^*L^\alpha Q \rightarrow p^*L^\beta Q, \\ \mathbb{L}_{1^*\alpha}^\beta \otimes p^*\pi^*G \otimes p^*L^\alpha Q &\rightarrow \mathbb{L}_{1^*\alpha}^\beta \otimes p^*Q^\vee \otimes p^*L^\alpha Q \rightarrow p^*L^\beta Q \end{aligned} \tag{6.1}$$

for all  $\beta$  such that  $\alpha \nearrow \beta$ , respectively,  $\beta \nearrow \alpha$ .

Thus,  $K[\mathbb{Y}]$  acts on  $\mathcal{N}$  and in fact  $K[\mathbb{Y}_{l,m-l}]$  acts since  $\mathcal{N}$  contains only bundles  $\mathcal{N}_\alpha$  with  $\alpha \in B_{l,m-l}$ .  $\blacksquare$

To identify the kernel of the homomorphism of Proposition 6.4, observe that if  $\gamma$  is obtained by adding two boxes to  $\alpha$ , we have canonical decompositions into one-dimensional spaces

$$\mathbb{L}_{11\alpha}^\gamma = \mathbb{L}_{[2]\alpha}^\gamma \oplus \mathbb{L}_{[11]\alpha}^\gamma, \tag{6.2}$$

$$\mathbb{L}_{11\alpha}^\gamma = \bigoplus_{\alpha \nearrow \beta \nearrow \gamma} \mathbb{L}_{1\beta}^\gamma \otimes \mathbb{L}_{1\alpha}^\beta. \tag{6.3}$$



If the two boxes are added in the same row, respectively, column, then  $\mathbb{L}_{[11]\alpha}^\gamma = 0$ , respectively,  $\mathbb{L}_{[2]\alpha}^\gamma = 0$ , and the sum in (6.3) has only one summand. If, however, the two boxes are in different rows and columns, each of (6.2) and (6.3) provides the two-dimensional space  $\mathbb{L}_{11\alpha}^\gamma$  with a basis defined up to scalar multiples, but these bases are not the same, even up to scalars.

Similarly, we have the canonical decompositions

$$\mathbb{L}_{1^*1^*\gamma}^\alpha = \mathbb{L}_{[2]^*\gamma}^\alpha \otimes \mathbb{L}_{[11]^*\gamma}^\alpha, \tag{6.4}$$

$$\mathbb{L}_{1^*1^*\gamma}^\alpha = \bigoplus_{\alpha \nearrow \beta \nearrow \gamma} \mathbb{L}_{1^*\beta}^\alpha \otimes \mathbb{L}_{1^*\gamma}^\beta, \tag{6.5}$$

which again define two essentially different bases for  $\mathbb{L}_{1^*1^*\gamma}^\alpha$ .

If  $\gamma$  is obtained by moving a box in  $\alpha$  from row  $i$  to row  $j$ , then we have canonical isomorphisms

$$\mathbb{L}_{11^*\alpha}^\gamma = \bigoplus_{\beta} \mathbb{L}_{1\beta}^\gamma \otimes \mathbb{L}_{1^*\alpha}^\beta, \tag{6.6}$$

$$\mathbb{L}_{1^*1\alpha}^\gamma = \bigoplus_{\beta} \mathbb{L}_{1^*\beta}^\gamma \otimes \mathbb{L}_{1\alpha}^\beta. \tag{6.7}$$

As long as  $i \neq j$ , the space  $\mathbb{L}_{11^*\alpha}^\gamma$  is again one-dimensional and acquires two different basis elements from the sums (6.6) and (6.7), each of which has only one non-zero summand.

Finally, for each partition  $\alpha$  the dimension of the space  $\mathbb{L}_{11^*\alpha}^\alpha$  is equal to the number of addable boxes in  $\alpha$ , or equivalently the number of ways to remove a box from  $\alpha$  and obtain a dominant weight. (We allow the removal of a “phantom” box below the lowest row of  $\alpha$ .) Again this space has a canonical decomposition into one-dimensional spaces

$$\mathbb{L}_{11^*\alpha}^\alpha = \bigoplus_{\beta} \mathbb{L}_{1\beta}^\alpha \otimes \mathbb{L}_{1^*\alpha}^\beta, \tag{6.8}$$

$$\mathbb{L}_{1^*1\alpha}^\alpha = \bigoplus_{\beta} \mathbb{L}_{1^*\beta}^\alpha \otimes \mathbb{L}_{1\alpha}^\beta. \tag{6.9}$$

We use these decompositions (6.2)–(6.9) of the universal coefficient spaces to define the relations on  $\mathbb{Y}_{l,m-l}$ .

**Definition 6.5.** We impose relations  $I$  on the Young quiver  $\mathbb{Y}$  generated by the following subspaces of  $K[\mathbb{Y}]_2$ .

(i) For  $\gamma$  obtained by adding two boxes to  $\alpha$ ,

$$\ker \left( \bigoplus_{\alpha \nearrow \beta \nearrow \gamma} \mathbb{L}_{1^* \beta}^\gamma \otimes F^\vee \otimes \mathbb{L}_{1\alpha}^\beta \otimes F^\vee \longrightarrow \begin{array}{c} \mathbb{L}_{[2]_2\alpha}^\gamma \otimes \text{Sym}_2 F^\vee \\ \oplus \\ \mathbb{L}_{[11]_2\alpha}^\gamma \otimes \wedge^2 F^\vee \end{array} = \mathbb{L}_{11\alpha}^\gamma \otimes F^\vee \otimes F^\vee \right).$$

(ii) For  $\gamma$  obtained by deleting two boxes from  $\alpha$ ,

$$\ker \left( \bigoplus_{\alpha \nearrow \beta \nearrow \gamma} \mathbb{L}_{1^* \beta}^\alpha \otimes G \otimes \mathbb{L}_{1^* \gamma}^\beta \otimes G \longrightarrow \begin{array}{c} \mathbb{L}_{[2]^* \gamma}^\alpha \otimes \text{Sym}_2 G \\ \oplus \\ \mathbb{L}_{[11]^* \gamma}^\alpha \otimes \wedge^2 G \end{array} = \mathbb{L}_{1^* 1^* \gamma}^\alpha \otimes G \otimes G \right).$$

(iii) For  $\gamma$  obtained by moving a box in  $\alpha$  from row  $i$  to row  $j \neq i$ ,

$$\ker \left( \begin{array}{c} \mathbb{L}_{1\alpha-\epsilon_i}^\gamma \otimes F^\vee \otimes \mathbb{L}_{1^* \alpha}^{\alpha-\epsilon_i} \otimes G \\ \oplus \\ \mathbb{L}_{1^* \alpha+\epsilon_j}^\gamma \otimes G \otimes \mathbb{L}_{1\alpha}^{\alpha+\epsilon_j} \otimes F^\vee \end{array} \longrightarrow \mathbb{L}_{11^* \alpha}^\gamma \otimes F^\vee \otimes G \right).$$

(iv) For each partition  $\alpha$ ,

$$\ker \left( \begin{array}{c} \bigoplus_{\alpha \nearrow \beta} \mathbb{L}_{1^* \beta}^\alpha \otimes G \otimes \mathbb{L}_{1\alpha}^\beta \otimes F^\vee \\ \oplus \\ \bigoplus_{\beta \nearrow \alpha} \mathbb{L}_{1\beta}^\alpha \otimes F^\vee \otimes \mathbb{L}_{1^* \alpha}^\beta \otimes G \end{array} \longrightarrow \mathbb{L}_{11^* \alpha}^\alpha \otimes F^\vee \otimes G \right).$$

In each case the indicated maps are defined by the canonical decompositions (6.2)–(6.9), together with the natural surjections  $F^\vee \otimes F^\vee \rightarrow \text{Sym}_2 F^\vee$ ,  $F^\vee \otimes F^\vee \rightarrow \wedge^2 F^\vee$ , etc.

We apply these relations to the truncated Young quiver  $\mathbb{Y}_{l,m-l}$  as well, keeping in mind that any path traveling outside  $B_{l,m-l}$  is zero.  $\square$

**Proposition 6.6.** The relations listed in Definition 6.5 act trivially on  $\mathcal{N}$ , thus induce a ring homomorphism  $K[\mathbb{Y}_{l,m-l}]/(\text{relations}) \rightarrow \text{End}_{\mathcal{O}_{\mathbb{Z}}}(\mathcal{N})$ .  $\square$

**Proof.** This amounts to checking in each case that the composition of two arrows in the quiver maps to the Hom-space by the obvious projection. For example, in case (i) the composition of maps  $\mathcal{N}_\alpha \rightarrow \mathcal{N}_\beta \rightarrow \mathcal{N}_\gamma$ , where  $\alpha \nearrow \beta \nearrow \gamma$ , is given by the pullback of the evaluation

$$\text{Hom}(Q \otimes L^\beta Q, L^\gamma Q) \otimes Q \otimes \text{Hom}(Q \otimes L^\alpha Q, L^\beta Q) \otimes Q \otimes L^\alpha Q \rightarrow L^\gamma Q.$$

Shuffling the tensor products around and using the fixed splitting  $\mathcal{Q} \otimes \mathcal{Q} = \text{Sym}_2 \mathcal{Q} \oplus \wedge^2 \mathcal{Q}$ , we can rewrite this as

$$\text{Hom}((\text{Sym}_2 \mathcal{Q} \oplus \wedge^2 \mathcal{Q}) \otimes L^\alpha \mathcal{Q}, L^\gamma \mathcal{Q}) \otimes (\text{Sym}_2 \mathcal{Q} \oplus \wedge^2 \mathcal{Q}) \otimes L^\alpha \mathcal{Q} \longrightarrow L^\gamma \mathcal{Q},$$

so that the map is nothing but the natural projection. Similar manipulations take care of the other cases. ■

To show that the vector spaces of relations defined in Definition 6.5, after restriction to  $\mathbb{Y}_{l,m-l}$ , have the dimensions predicted by (5.1), we must verify that the maps

$$\bigoplus_{\beta \in B_{l,m-l}} \mathbb{L}_{1\beta}^\gamma \otimes \mathbb{L}_{1\alpha}^\beta \longrightarrow \mathbb{L}_{[2]\alpha}^\gamma \oplus \mathbb{L}_{[11]\alpha}^\gamma, \tag{6.10}$$

$$\bigoplus_{\beta \in B_{l,m-l}} \mathbb{L}_{1^*\beta}^\alpha \otimes \mathbb{L}_{1^*\gamma}^\beta \longrightarrow \mathbb{L}_{[2]^*\gamma}^\alpha \oplus \mathbb{L}_{[11]^*\gamma}^\alpha, \tag{6.11}$$

$$(\mathbb{L}_{1^{\alpha-\epsilon_i}}^{\alpha-\epsilon_i+\epsilon_j} \otimes \mathbb{L}_{1^*\alpha}^{\alpha-\epsilon_i}) \oplus (\mathbb{L}_{1^*\alpha+\epsilon_j}^{\alpha-\epsilon_i+\epsilon_j} \otimes \mathbb{L}_{1\alpha}^{\alpha+\epsilon_j}) \longrightarrow \mathbb{L}_{11^*\alpha}^{\alpha-\epsilon_i+\epsilon_j}, \tag{6.12}$$

$$\bigoplus_{\substack{\alpha \nearrow \beta \\ \beta \in B_{l,m-l}}} \mathbb{L}_{1^*\beta}^\alpha \otimes \mathbb{L}_{1\alpha}^\beta \oplus \bigoplus_{\substack{\beta \nearrow \alpha \\ \beta \in B_{l,m-l}}} \mathbb{L}_{1\beta}^\alpha \otimes \mathbb{L}_{1^*\alpha}^\beta \longrightarrow \mathbb{L}_{11^*\alpha}^\alpha, \tag{6.13}$$

obtained by restricting all  $\alpha, \beta, \gamma, \alpha - \epsilon_i$  and  $\alpha + \epsilon_j$  to lie in the box  $B_{l,m-l}$ , remain surjective. Our proof of this fact relies on an explicit computation relating two bases for  $\mathbb{L}_{11^*\alpha}^\alpha$ . In order not to disrupt the flow of the argument, we postpone this computation to the next section. See Corollary 7.16.

**Lemma 6.7.** Assume  $m - l > 1$ . The restricted maps (6.10)–(6.13) are surjective. The spaces of relations between two vertices  $\alpha, \gamma \in B_{l,m-l}$  of  $\mathbb{Y}_{l,m-l}$  are thus given by

$$\left\{ \begin{array}{ll} \text{Sym}_2 F^\vee & \text{if } \alpha \nearrow \nearrow \gamma, \text{ two boxes in a column,} \\ \wedge^2 F^\vee & \text{if } \alpha \nearrow \nearrow \gamma, \text{ two boxes in a row,} \\ \text{Sym}_2 F^\vee \oplus \wedge^2 F^\vee \cong F^\vee \otimes F^\vee & \text{if } \alpha \nearrow \nearrow \gamma, \text{ two disconnected boxes,} \\ F^\vee \otimes G & \text{if } \alpha \neq \gamma, \text{ and } \alpha \nearrow \beta, \gamma \nearrow \beta, \text{ for some } \beta \text{ with } \beta_1 \leq m - l, \\ (F^\vee \otimes G)^{\oplus(t(\alpha)-1)} & \text{if } \alpha = \gamma, \\ \text{Sym}_2 G & \text{if } \gamma \nearrow \nearrow \alpha, \text{ two boxes in a column,} \\ \wedge^2 G & \text{if } \gamma \nearrow \nearrow \alpha, \text{ two boxes in a row,} \\ \text{Sym}_2 G \oplus \wedge^2 G \cong G \otimes G & \text{if } \gamma \nearrow \nearrow \alpha, \text{ two disconnected boxes,} \end{array} \right.$$

where  $t(\alpha)$  is the number of ways to add a box to  $\alpha$  without making any row longer than  $m - l$ . □

**Proof.** The statements about (6.10)–(6.12) are clear, since if one of the intermediate partitions lies outside  $B_{l,m-l}$ , then so does  $\gamma$  and the target of the map vanishes.

Fix  $\alpha \in B_{l,m-l}$ . There is exactly one dominant weight  $\rho \notin B_{l,m-l}$  such that  $\rho \nearrow \alpha$ , namely the result of deleting the phantom box below the lowest row of  $\alpha$ . Thus, the sum

$$\bigoplus_{\substack{\beta \nearrow \alpha \\ \beta \in B_{l,m-l}}} \mathbb{L}_{1\beta}^\alpha \otimes \mathbb{L}_{1^*\alpha}^\beta$$

has  $r(\alpha) - 1$  summands, where  $r(\alpha)$  is the total number of ways to add a box to  $\alpha$ .

There are two cases, depending on whether the first row of  $\alpha$  has maximal length. If  $\alpha_1 < m - l$ , then there are no  $\beta \notin B_{l,m-l}$  with  $\alpha \nearrow \beta$ , so that

$$\bigoplus_{\substack{\alpha \nearrow \beta \\ \beta \in B_{l,m-l}}} \mathbb{L}_{1^*\beta}^\alpha \otimes \mathbb{L}_{1\alpha}^\beta \longrightarrow \mathbb{L}_{11^*\alpha}^\alpha$$

is an isomorphism, and (6.13) is surjective. In this case, we have  $t(\alpha) = r(\alpha)$ , and the kernel of (6.13) has dimension  $r(\alpha) - 1 = t(\alpha) - 1$ .

If on the other hand  $\alpha_1 = m - l$ , then there is exactly one partition  $\sigma \notin B_{l,m-l}$  with  $\alpha \nearrow \sigma$ . To show that (6.13) is onto, it suffices to see that the images of the one-dimensional spaces  $\mathbb{L}_{1^*\sigma}^\alpha \otimes \mathbb{L}_{1\alpha}^\sigma$  and  $\mathbb{L}_{1\rho}^\alpha \otimes \mathbb{L}_{1^*\alpha}^\rho$  do not coincide in  $\mathbb{L}_{11^*\alpha}^\alpha$ . This follows from Corollary 7.16; the matrix relating the two Pieri bases for  $\mathbb{L}_{11^*\alpha}^\alpha$  has no non-zero entries, so no element of one basis is a scalar multiple of an element of the other basis. Now  $t(\alpha) = r(\alpha) - 1$  in this case, so that the kernel of (6.13) has dimension  $(r(\alpha) - 1) + (r(\alpha) - 1) - r(\alpha) = r(\alpha) - 2 = t(\alpha) - 1$ . ■

**Remark 6.8.** In the case  $m - l = 1$ , Lemma 6.7 fails; there are cubic minimal relations in the quiver [5, Remark 7.6]. See Proposition A.10 for another point of view on their disappearance when  $m - l > 1$ . □

**Theorem 6.9.** Assume  $m - l > 1$ . The homomorphism  $K[\mathbb{Y}_{l,m-l}]/(\text{relations}) \longrightarrow A = \text{End}_{\mathcal{O}_{\mathbb{Z}}}(\mathcal{N})$  is an isomorphism. Thus,  $A$  is isomorphic to the bound path algebra of the Young quiver  $\mathbb{Y}_{l,m-l}$  having vertices  $\alpha \in B_{l,m-l}$  and arrows  $\alpha \longrightarrow \beta$  indexed by bases for

$$\begin{cases} F^\vee & \text{if } \alpha \nearrow \beta \text{ and} \\ G & \text{if } \beta \nearrow \alpha, \end{cases}$$

with Pieri relations as indicated in Lemma 6.7. □

**Proof.** The computation of  $\text{Ext}_A^{0,1,2}(S_\beta, S_\alpha)$  for simple  $A$ -modules  $S_\alpha$  and  $S_\beta$  in Example 5.1 shows that  $A$  is a quotient of  $K[\mathbb{Y}_{l,m-l}]$  with relations generated by  $(\text{Ext}_A^2(S_\gamma, S_\alpha)^\vee)_{\alpha,\gamma}$ . We also have a surjection  $K[\mathbb{Y}_{l,m-l}]/(\text{relations}) \rightarrow A$ . The induced endomorphism  $K[\mathbb{Y}_{l,m-l}] \rightarrow K[\mathbb{Y}_{l,m-l}]$  may not be the identity, but the map  $K[\mathbb{Y}_{l,m-l}] \rightarrow A$  is  $\text{GL}(F) \times \text{GL}(G)$ -equivariant, and there is a unique such map up to scaling arrows. We may therefore rescale to assume that the induced endomorphism of  $K[\mathbb{Y}_{l,m-l}]$  is the identity.

Write  $I$  for the ideal of relations. Take graded pieces of degree 2 to obtain the following commutative diagram of vector spaces.

$$\begin{array}{ccccccc}
 0 & \longrightarrow & I_2 & \longrightarrow & K[\mathbb{Y}_{l,m-l}]_2 & \longrightarrow & K[\mathbb{Y}_{l,m-l}]_2/I_2 \longrightarrow 0 \\
 & & \downarrow \text{dashed} & & \parallel & & \downarrow \\
 0 & \longrightarrow & \langle \text{Ext}_A^2(S_\gamma, S_\alpha)^\vee \rangle_{\alpha,\gamma} & \longrightarrow & K[\mathbb{Y}_{l,m-l}]_2 & \longrightarrow & A_2 \longrightarrow 0
 \end{array}$$

Now, the dashed arrow is injective, whence an isomorphism since  $I_2$  has the same dimension as  $\langle \text{Ext}_A^2(S_\gamma, S_\alpha)^\vee \rangle_{\alpha,\gamma}$  by Example 5.1. It follows that  $K[\mathbb{Y}_{l,m-l}] \rightarrow A$  is an isomorphism. ■

### 7 Pieri Systems

To extract a really explicit description of the non-commutative desingularization  $A$  from Theorem 6.9, as well as to finish the proof of Lemma 6.7 and thereby Theorem 6.9, we must compute the non-diagonal surjections  $(F^\vee \otimes F^\vee)^2 \rightarrow F^\vee \otimes F^\vee$ ,  $(G \otimes G)^2 \rightarrow G \otimes G$ , and  $(F^\vee \otimes G) \oplus (G \otimes F^\vee) \rightarrow F^\vee \otimes G$  in Definition 6.5. Equivalently, we must choose bases for the one-dimensional universal vector spaces appearing in the canonical decompositions

$$\begin{aligned}
 \mathbb{L}_{[2]^\alpha}^\gamma \oplus \mathbb{L}_{[11]^\alpha}^\gamma &= \mathbb{L}_{11^\alpha}^\gamma = \bigoplus_{\alpha \nearrow \beta \nearrow \gamma} \mathbb{L}_{1^\beta}^\gamma \otimes \mathbb{L}_{1^\alpha}^\beta, \\
 \mathbb{L}_{[2]^{*\gamma}}^\alpha \oplus \mathbb{L}_{[11]^{*\gamma}}^\alpha &= \mathbb{L}_{1^*1^\gamma}^\alpha = \bigoplus_{\alpha \nearrow \beta \nearrow \gamma} \mathbb{L}_{1^*\beta}^\alpha \otimes \mathbb{L}_{1^*\gamma}^\beta, \\
 \bigoplus_\beta \mathbb{L}_{1^\beta}^\gamma \otimes \mathbb{L}_{1^*\alpha}^\beta &= \mathbb{L}_{1^*1^\alpha}^\gamma = \bigoplus_\beta \mathbb{L}_{1^*\beta}^\gamma \otimes \mathbb{L}_{1^\alpha}^\beta, \\
 \bigoplus_\beta \mathbb{L}_{1^\beta}^\alpha \otimes \mathbb{L}_{1^*\alpha}^\beta &= \mathbb{L}_{1^*1^\alpha}^\alpha = \bigoplus_\beta \mathbb{L}_{1^*\beta}^\alpha \otimes \mathbb{L}_{1^\alpha}^\beta,
 \end{aligned} \tag{7.1}$$

where in the first two equations  $\gamma$  is obtained by adding two boxes to  $\alpha$  and in the third equation  $\alpha$  and  $\gamma$  are related by moving a box from one row to another.

There is no canonical way to make these choices, but there is a coherent set of choices due to Olver [16, 18], see also [19, 21]. We do not give the details of the intricate construction of Olver’s maps, but instead we characterize the choices one can make and show how they determine the scalars in the quiver.

It is more convenient below to work with  $\mathbb{L}_\beta^{1\alpha}$  rather than the canonically isomorphic space  $\mathbb{L}_{1+\beta}^\alpha$ . This replacement gives isomorphic maps to those in Definition 6.5, so makes no difference for the purpose of identifying the relations.

Throughout this section,  $K$  is a field of characteristic zero and  $V$  is a vector space of dimension  $d$ . Let  $\epsilon_i$  be the vector  $(0, \dots, 0, 1, 0, \dots, 0)$  with 1 at the  $i$ th position.

Pieri’s theorem tells us

$$V \otimes L^\alpha V \cong \bigoplus_i L^{\alpha+\epsilon_i} V \otimes \mathbb{L}_{\alpha+\epsilon_i}^{1\alpha},$$

where  $\mathbb{L}_{\alpha+\epsilon_i}^{1\alpha}$  is one-dimensional if  $\alpha + \epsilon_i$  is still a partition, and zero otherwise. A *Pieri system* is a family of non-zero  $\text{GL}(V)$ -equivariant linear maps

$$\chi_{\alpha,i}: L^{\alpha+\epsilon_i} V \longrightarrow V \otimes L^\alpha V.$$

These maps are unique up to non-zero scalars. One easily deduces that for  $i < j$  such that  $\alpha + \epsilon_i$  and  $\alpha + \epsilon_j$  are partitions one has that

$$\text{Hom}_{\text{GL}(V)}(L^{\alpha+\epsilon_i+\epsilon_j} V, V \otimes V \otimes L^\alpha V)$$

is two-dimensional with basis

$$\chi_{\alpha,i,j} = (1 \otimes \chi_{\alpha,i}) \circ \chi_{\alpha+\epsilon_i,j},$$

$$\chi_{\alpha,j,i} = (1 \otimes \chi_{\alpha,j}) \circ \chi_{\alpha+\epsilon_j,i}.$$

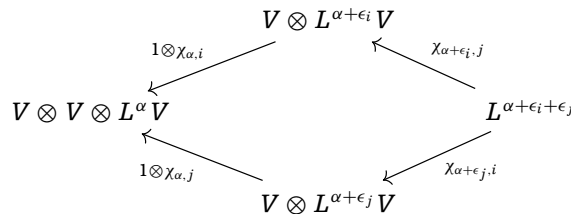

Let  $\chi_{\alpha,i,j}^+$  and  $\chi_{\alpha,i,j}^-$  be obtained by postcomposing  $\chi_{\alpha,i,j}$ , respectively, with the symmetrization map  $V \otimes V \longrightarrow \text{Sym}^2 V$  and the anti-symmetrization map  $V \otimes V \longrightarrow \wedge^2 V$ . By Pieri’s theorem for symmetric and exterior powers, we also know that

both  $\text{Hom}_{\text{GL}(V)}(L^{\alpha+\epsilon_i+\epsilon_j}V, \text{Sym}^2V \otimes L^\alpha V)$  and  $\text{Hom}_{\text{GL}(V)}(L^{\alpha+\epsilon_i+\epsilon_j}V, \wedge^2V \otimes L^\alpha V)$  are one-dimensional. Furthermore, these spaces are clearly spanned by  $\{\chi_{\alpha,i,j}^+, \chi_{\alpha,j,i}^+\}$  and  $\{\chi_{\alpha,i,j}^-, \chi_{\alpha,j,i}^-\}$ , respectively. This means we can define scalars (well defined but not a priori finite or non-zero at this stage)

$$\gamma_{\alpha,i,j}^+ = \frac{\chi_{\alpha,j,i}^+}{\chi_{\alpha,i,j}^+}, \quad \gamma_{\alpha,i,j}^- = \frac{\chi_{\alpha,j,i}^-}{\chi_{\alpha,i,j}^-}.$$

We call  $(\gamma_{\alpha,i,j}^+)$ ,  $(\gamma_{\alpha,i,j}^-)$  the (*symmetric, exterior*) *characteristic ratios* of the Pieri system  $(\chi_{\alpha,i})$ .

We say that two Pieri systems  $\chi, \chi'$  are *equivalent* (notation:  $\chi \sim \chi'$ ) if there are  $(c_\alpha)_\alpha \in K^*$ , with  $\alpha$  running through the partitions, such that

$$\chi'_{\alpha,i} = \frac{c_{\alpha+\epsilon_i}}{c_\alpha} \chi_{\alpha,i}.$$

Clearly, two equivalent Pieri systems have the same characteristic ratios.

The following summarizes what we know about Pieri systems.

**Proposition 7.1.** Let  $(\chi_{\alpha,i})_{\alpha,i}$  be a Pieri system with characteristic ratios  $(\gamma_{\alpha,i,j}^+)_{\alpha,i,j}$ ,  $(\gamma_{\alpha,i,j}^-)_{\alpha,i,j}$ .

- (i) The characteristic ratios are finite and non-zero.
- (ii) We have

$$\frac{\gamma_{\alpha,i,j}^+}{\gamma_{\alpha,i,j}^-} = \frac{u-1}{u+1},$$

where

$$u = \frac{1}{(i - \alpha_i - 1) - (j - \alpha_j - 1)}. \tag{7.2}$$

We have written  $u$  in this peculiar way to emphasize how it depends on the added boxes  $(i, \alpha_i + 1)$ ,  $(j, \alpha_j + 1)$ .

- (iii) Assume that  $\alpha$  is a partition and  $i < j < k$  are such that  $\alpha + \epsilon_i, \alpha + \epsilon_j, \alpha + \epsilon_k$  are partitions. Then we have

$$\begin{aligned} \gamma_{\alpha+\epsilon_k,ij}^+ \gamma_{\alpha,ik}^+ \gamma_{\alpha+\epsilon_i,jk}^+ &= \gamma_{\alpha,jk}^+ \gamma_{\alpha+\epsilon_j,ik}^+ \gamma_{\alpha,ij}^+, \\ \gamma_{\alpha+\epsilon_k,ij}^- \gamma_{\alpha,ik}^- \gamma_{\alpha+\epsilon_i,jk}^- &= \gamma_{\alpha,jk}^- \gamma_{\alpha+\epsilon_j,ik}^- \gamma_{\alpha,ij}^-. \end{aligned} \tag{7.3}$$

- (iv) Two Pieri systems with the same characteristic ratios are equivalent.
- (v) We can fix either the symmetric or the exterior characteristic ratios of a Pieri system arbitrarily provided they satisfy (7.3). □

**Remark 7.2.** Olver constructs an explicit Pieri system, which we call the *classical* system, from the combinatorics of Young tableaux. Part (i) of the theorem appears in [18, Lemma 8.3] and in [16, Section 3], where it is stated for the inverse maps  $\varphi_{\alpha+\epsilon_i, i}: V \otimes L^\alpha V \rightarrow L^{\alpha+\epsilon_i} V$  (see Definition 7.10). A detailed proof of the non-vanishing of  $\chi_{\alpha, i, j}^+$  appears in [21, Lemma 1.6], and their proof is easily modified to apply as well to  $\chi_{\alpha, i, j}^-$ .

Sam and Weyman also compute [21, Corollary 1.8] the scalar multipliers  $\gamma_{\alpha, i, j}^\pm$  for the classical system (though the expression in [21] for  $\gamma^-$  should be preceded by a minus sign), and Sam’s “PieriMaps” package implements the calculation of  $\chi^+$  in Macaulay2 [20].

It follows from part (v) that we may set  $\gamma^+ = 1$  or  $\gamma^- = 1$ , but not both. Indeed, the canonical (basis-free) isomorphisms

$$\mathbb{L}_{\alpha+\epsilon_i+\epsilon_j}^{[2]\alpha} \oplus \mathbb{L}_{\alpha+\epsilon_i+\epsilon_j}^{[11]\alpha} = \mathbb{L}_{\alpha+\epsilon_i+\epsilon_j}^{11\alpha} = (\mathbb{L}_{\alpha+\epsilon_i+\epsilon_j}^{1\alpha+\epsilon_i} \otimes \mathbb{L}_{\alpha+\epsilon_i}^{1\alpha}) \oplus (\mathbb{L}_{\alpha+\epsilon_i+\epsilon_j}^{1\alpha+\epsilon_j} \otimes \mathbb{L}_{\alpha+\epsilon_j}^{1\alpha})$$

define four one-dimensional subspaces of the two-dimensional space  $\mathbb{L}_{\alpha+\epsilon_i+\epsilon_j}^{11\alpha}$ . Such a configuration is essentially classified by a single invariant, the cross-ratio, which is independent (up to sign) of all choices. This is the origin of the constant in part (ii) of the theorem. In [18, Section 8], Olver shows how to renormalize the classical system so that  $\gamma^+ = 1$ .

Note also that (7.3) is automatically satisfied if  $\gamma_{\alpha, i, j}^\pm$  depends only on the added boxes  $(i, \alpha_i + 1)$ ,  $(j, \alpha_j + 1)$ . In other words, we may put

$$\gamma_{\alpha, i, j}^+ = 1 - u, \quad \gamma_{\alpha, i, j}^- = -(1 + u)$$

with  $u$  as in (7.2). These happen to be the characteristic ratios for the classical system. See Lemma 7.7 and Remark 7.8.  $\square$

### 7.1 Schur–Weyl duality

For  $\alpha$  a partition with  $|\alpha| = n$ , let  $H_\alpha$  be the corresponding irreducible representation of  $S_n$ . Consider the contravariant functor  $\mathbb{D}: \text{Rep}(S_n) \rightarrow \text{Rep}(\text{GL}(V))$  which sends  $H$  to  $\text{Hom}_{S_n}(H, V^{\otimes n})$ . Let  $\mathcal{S}$  be the full subcategory of  $\text{Rep}(S_n)$  spanned by the  $H_\alpha$  such that  $\alpha$  has  $> d$  parts. Then  $\mathbb{D}$  defines a duality between  $\text{Rep}(S_n)/\mathcal{S}$  and the full subcategory of  $\text{Rep}(\text{GL}(V))$  consisting of polynomial representations. We also have

$$\mathbb{D}(\text{Ind}_{S_a \times S_b}^{S_{a+b}}(H_1 \otimes H_2)) = \mathbb{D}(H_1) \otimes \mathbb{D}(H_2)$$

for  $H_1, H_2$  representations of  $S_a, S_b$ , respectively.



We may take  $L^\alpha V = \mathbb{D}(H_\alpha)$ . For partitions  $\lambda^1, \dots, \lambda^k, \alpha$ , put

$$\mathbb{V}_\alpha^{\lambda^1 \dots \lambda^k} = \text{Hom}_{S_{c_1} \times \dots \times S_{c_k}}(H_{\lambda^1} \otimes \dots \otimes H_{\lambda^k}, \text{Res}_{S_{c_1} \times \dots \times S_{c_k}}^{S_a} H_\alpha),$$

where  $|\lambda^i| = c_i$ ,  $|\alpha| = a$ . Then

$$\begin{aligned} \mathbb{L}_\alpha^{\lambda^1 \dots \lambda^k} &= \text{Hom}_{\text{GL}(V)}(\mathbb{D}(H_\alpha), \mathbb{D}(H_{\lambda^1}) \otimes \dots \otimes \mathbb{D}(H_{\lambda^k})) \\ &= \text{Hom}_{S_a}(\text{Ind}_{S_{c_1} \times \dots \times S_{c_k}}^{S_a}(H_{\lambda^1} \otimes \dots \otimes H_{\lambda^k}), H_\alpha) \\ &= \text{Hom}_{S_{c_1} \times \dots \times S_{c_k}}(H_{\lambda^1} \otimes \dots \otimes H_{\lambda^k}, \text{Res}_{S_{c_1} \times \dots \times S_{c_k}}^{S_a} H_\alpha) \\ &= \mathbb{V}_\alpha^{\lambda^1 \dots \lambda^k}. \end{aligned}$$

We will denote the so obtained canonical isomorphism  $\mathbb{V}_\alpha^{\lambda^1 \dots \lambda^k} \cong \mathbb{L}_\alpha^{\lambda^1 \dots \lambda^k}$  also by  $\mathbb{D}$ . As in Proposition 6.2, we have canonical isomorphisms:

$$\bigoplus_\lambda \mathbb{L}_\alpha^{\beta\lambda} \otimes \mathbb{L}_\lambda^{\delta\epsilon} \longrightarrow \mathbb{L}_\alpha^{\beta\delta\epsilon}, \quad \varphi_1 \otimes \varphi_2 \mapsto (1 \otimes \varphi_2) \circ \varphi_1.$$

Likewise we have canonical isomorphisms

$$\bigoplus_\lambda \mathbb{V}_\alpha^{\beta\lambda} \otimes \mathbb{V}_\lambda^{\delta\epsilon} \longrightarrow \mathbb{V}_\alpha^{\beta\delta\epsilon}, \quad \theta_1 \otimes \theta_2 \mapsto (1 \otimes \theta_1) \circ \theta_2.$$

One easily checks that these decompositions are compatible, that is,

$$\mathbb{D}((1 \otimes \theta_1) \circ \theta_2) = (1 \otimes \mathbb{D}(\theta_2)) \circ \mathbb{D}(\theta_1).$$

In particular, we see that the canonical decomposition

$$\mathbb{L}_\alpha^{1 \dots 1} = \bigoplus_{\lambda^1, \dots, \lambda^n = \alpha} \mathbb{L}_{\lambda^1}^1 \otimes \mathbb{L}_{\lambda^2}^{1\lambda^1} \otimes \dots \otimes \mathbb{L}_{\lambda^n}^{1\lambda^{n-1}} \tag{7.4}$$

is the image under  $\mathbb{D}$  of the corresponding canonical decomposition

$$H_\alpha = \mathbb{V}_\alpha^{1 \dots 1} = \bigoplus_{\lambda^1, \dots, \lambda^n = \alpha} \mathbb{V}_{\lambda^1}^1 \otimes \mathbb{V}_{\lambda^2}^{1\lambda^1} \otimes \dots \otimes \mathbb{V}_{\lambda^n}^{1\lambda^{n-1}}. \tag{7.5}$$

The right-hand side of (7.5) is precisely the decomposition into one-dimensional subspaces of  $H_\alpha$  given by a Young basis. This observation is due to Jucys [13, 14] and is the basis for the new approach to the representation theory of the symmetric group in [17, Equation (1.2)].

Below we follow the setup of [17] but we formulate the results directly in terms of the decomposition (7.4).

### 7.2 The Pieri complex

The claims (iv) and (v) in Proposition 7.1 can be proved directly, but this is notationally somewhat cumbersome. Therefore, we prefer to deduce them from some topological considerations. This is based on the fact that a certain cubical complex is contractible.

We define the *Pieri complex*  $\mathbb{P}$  as the cubical set whose non-degenerate  $h$ -cubes are given by tuples  $(\alpha, i_1, \dots, i_h)$  such that  $1 \leq i_1 < \dots < i_h \leq d$  and such that  $\alpha$  is a partition with at most  $d$  parts with the property that for all  $1 \leq u \leq h$  we have that  $\alpha + \epsilon_{i_u}$  is also a partition. Thus, the vertices of  $\mathbb{P}$  are simply the partitions with at most  $d$  rows. We say that  $(\alpha', i'_1, \dots, i'_h)$  is a face of  $(\alpha, i_1, \dots, i_h)$  if either  $\alpha' = \alpha$  and  $\{i'_1, \dots, i'_h\} \subset \{i_1, \dots, i_h\}$ , or  $\alpha' = \alpha + \epsilon_{i_j}$  for some  $j \in \{1, \dots, u\}$  and  $\{i'_1, \dots, i'_h\} \subset \{i_1, \dots, \hat{i}_j, \dots, i_h\}$ . (The reader should have no difficulty visualizing  $(\alpha, i_1, \dots, i_h)$  as an  $h$ -dimensional hypercube; see Figure 1 for inspiration.) The following is our basic result about  $\mathbb{P}$ .

**Proposition 7.3.** The geometric realization  $|\mathbb{P}|$  of  $\mathbb{P}$  is contractible. □

**Proof.** By construction,  $|\mathbb{P}|$  is a CW complex. For  $s \geq 0$ , let  $\mathbb{P}_{\leq s} \subset \mathbb{P}$  be the subcomplex of faces that contain only vertices  $\alpha$  with  $|\alpha| \leq s$ . We first claim that  $|\mathbb{P}_{\leq s-1}|$  is a deformation retract of  $|\mathbb{P}_{\leq s}|$ .

If  $\alpha$  is a vertex in  $\mathbb{P}_{\leq s}$  but not in  $\mathbb{P}_{\leq s-1}$ , then it belongs to a unique maximal face  $\square = (\alpha', i_1, \dots, i_h)$  in  $\mathbb{P}_{\leq s}$  and all other vertices of  $\square$  lie in  $\mathbb{P}_{\leq s-1}$ . Thus, two different such maximal faces intersect each other in  $\mathbb{P}_{\leq s-1}$ .

Therefore, it is sufficient to retract each such maximal face individually to its intersection with  $|\mathbb{P}_{\leq s-1}|$ . The following picture shows this schematically for a 2-cube.

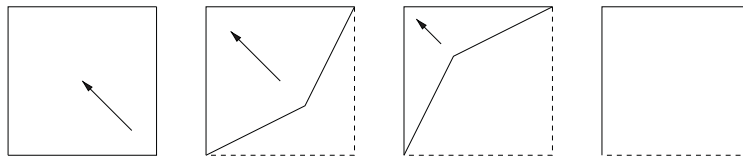

Hence, each  $|\mathbb{P}_{\leq s}|$  is contractible. So  $|\mathbb{P}|$  is contractible as well (see, e.g., [1, Theorem 5.1.35]). ■

### 7.3 Proof of Proposition 7.1

We start by constructing a particular Pieri system using the results of [17]. For simplicity, we encode a chain of partitions

$$\emptyset \nearrow \alpha^1 \nearrow \alpha^2 \nearrow \dots \nearrow \alpha^n = \alpha$$

by a standard tableau  $T$  of shape  $\alpha$  where  $\alpha^i$  is the shape of  $T_{\leq i}$  which is by definition the subtableau of  $T$  containing only the letters  $1, \dots, i$ . For a partition  $\alpha$ , we denote by  $\text{diag}(\alpha)$  the set of standard tableaux of shape  $\alpha$ . The symmetric group  $S_n$  partially acts on  $\text{diag}(\alpha)$  by permuting the entries of the tableaux. If  $T \in \text{diag}(\alpha)$ , then we write  $\alpha = |T|$ . We put

$$\mathbb{L}_T = \mathbb{L}_{\alpha^2}^{1\alpha^1} \otimes \dots \otimes \mathbb{L}_{\alpha^n}^{1\alpha^{n-1}}$$

so that (7.4) becomes

$$\mathbb{L}_{\alpha}^{1\dots 1} = \bigoplus_{T \in \text{diag}(\alpha)} \mathbb{L}_T.$$

Let  $T_{\alpha}$  be the tableau with  $1, \dots, \alpha_i$  in the first row,  $\alpha_i + 1, \dots, \alpha_1 + \alpha_2$  in the second row, and so on. We write  $T = w_T T_{\alpha}$  for  $w_T \in S_n$ . We put  $l(T) = l(w_T)$  (see [17, Remark 6.3]). If  $T \in \text{diag}(\alpha)$ , then a transposition  $s = (i, i + 1)$  is *admissible* with respect to  $T$  if  $i$  and  $i + 1$  are neither in the same row nor in the same column. We say that an admissible transposition is strongly admissible if it increases  $l(T)$ . This happens if and only if it moves the  $i + 1$  box upward.

Following [17], we fix a non-zero vector  $v_{T_{\alpha}}$  in  $\mathbb{L}_{T_{\alpha}}$  for every partition  $\alpha$ . For  $T \in \text{diag}(\alpha)$ , we define  $v_T \in \mathbb{L}_T$  as the projection of  $w_T v_{T_{\alpha}} \in \mathbb{L}_{\alpha}^{1\dots 1}$  on  $\mathbb{L}_T$ .

**Proposition 7.4** (see [17, Proposition 5, Equation (7.3), and (7.4)]). Let  $T \in \text{diag}(\alpha)$  and let  $s = (i, i + 1)$  be a transposition. Then the following hold.

- (i) If  $i$  and  $i + 1$  are in the same row in  $T$ , then

$$sv_T = v_T.$$

- (ii) If  $i$  and  $i + 1$  are in the same column in  $T$ , then

$$sv_T = -v_T.$$

- (iii) If  $s$  is strongly admissible with respect to  $T$  and  $T' = sT$ , then

$$sv_T = v_{T'} + w_T, \tag{7.6}$$

$$sv_{T'} = -w_{T'} + (1 - u^2)v_T$$

with

$$u = \frac{1}{(k - \alpha_k - 1) - (l - \alpha_l - 1)}$$

with  $k, l$  being the rows of  $i$  and  $i + 1$ , respectively. □

Note that the case where  $s$  is admissible but not strongly admissible follows by exchanging  $T$  and  $T'$ .

The following lemma is a slight extension of [17, Equation (7.2)].

**Lemma 7.5.** (i) Let  $w \in S_n$  and  $T \in \text{diag}(\alpha)$ . Then

$$wv_T = \sum_{R \in \text{diag}(\alpha), l(R) \leq l(T)+l(w)} \gamma_R v_R$$

for some  $\gamma_R \in \mathbb{Q}$ .

(ii) Assume in addition that  $w$  is a product of strongly admissible transpositions. Then

$$wv_T = v_{wT} + \sum_{R \in \text{diag}(\alpha), l(R) < l(wT)} \gamma_R v_R$$

for some  $\gamma_R \in \mathbb{Q}$ . □

**Proof.** Assertion (i) follows easily from Proposition 7.4 by writing  $w$  as a composition of transpositions.

For the second statement, write  $w = sw'$  where  $s$  is a strongly admissible transposition and  $w'$  is a product of strongly admissible transpositions. By induction, we have

$$w'v_T = v_{w'T} + \sum_{R \in \text{diag}(\alpha), l(R') < l(w'T)} \gamma'_{R'} v_{R'}$$

so that we obtain

$$\begin{aligned} wv_T &= sv_{w'T} + \sum_{R' \in \text{diag}(\alpha), l(R') < l(w'T)} \gamma'_{R'} sv_{R'} \\ &= v_{wT} + \mathbf{w}v_{w'T} + \sum_{R' \in \text{diag}(\alpha), l(R') < l(w'T)} \gamma'_{R'} sv_{R'} \\ &= v_{wT} + \sum_{R \in \text{diag}(\alpha), l(R) < l(wT)} \gamma_R v_R, \end{aligned}$$

where in the second line we have used (7.6) and in the third line we have invoked the first part of the lemma. ■

Assume now that  $T \in \text{diag}(\alpha)$  and that  $\beta = \alpha + \epsilon_i$  is a partition. Let  $T'$  be obtained from  $T$  by adjoining a box labeled  $n+1$  at the end of row  $i$ . Thus,  $T' \in \text{diag}(\beta)$ .

We now have  $v_T \in \mathbb{L}_T, v_{T'} \in \mathbb{L}_{T'}$ . Since  $\mathbb{L}_{T'} = \mathbb{L}_T \otimes \mathbb{L}_\beta^{1\alpha}$ , we may choose  $\chi_{T,i}^c \in \mathbb{L}_\beta^{1\alpha}$  such that  $v_T \otimes \chi_{T,i}^c$  and  $v_{T'}$  correspond to each other. The following key result makes everything work.

**Lemma 7.6.** The map  $\chi_{T,i}^c$  is independent of the choice of  $T \in \text{diag}(\alpha)$ . □

**Proof.** It is sufficient to prove that for any  $T$  we have  $\chi_{T,i}^c = \chi_{T'_\alpha,i}^c$ . Consider  $w_T \in S_n$  as an element of  $S_{n+1}$ . Let  $T'_\alpha$  be obtained from  $T_\alpha$  by adjoining a box labeled  $n+1$  at the end of row  $i$ . If we write  $w_T \in S_n$  as a product of strongly admissible transpositions, then it remains a product of strongly admissible transpositions with respect to  $T'_\alpha$ , when considered as an element of  $S_{n+1}$ . Furthermore, we have  $v_{T'} = w_T v_{T'_\alpha}$ .

Let  $i: \mathbb{L}_T \rightarrow \mathbb{L}_\alpha^{1\cdots 1}, p: \mathbb{L}_\alpha^{1\cdots 1} \rightarrow \mathbb{L}_T$  be, respectively, the injection and the projection and let  $c_{S,S'}: \mathbb{L}_S \rightarrow \mathbb{L}_{S'}$  be the linear morphism which sends  $v_S$  to  $v_{S'}$ . We have the following diagram.

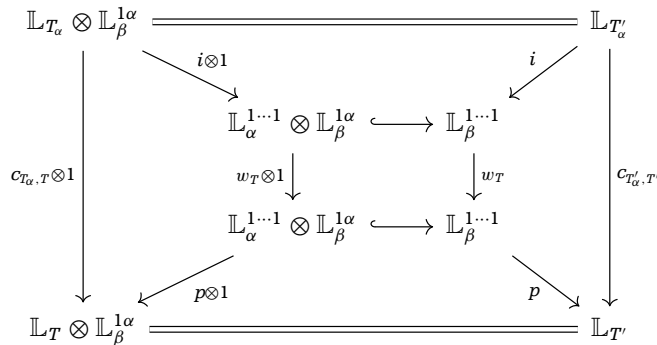

The commutativity of the leftmost trapezoid is by definition. The commutativity of the middle square is clear. The commutativity of the rightmost trapezoid follows from Lemma 7.5(ii). The commutativity of the upper and lower trapezoid is again by construction. From this, it is easy to see that the outer square is commutative which proves the lemma. ■

We now write  $\chi_{\alpha,i}^c = \chi_{T,i}^c$  for  $T \in \text{diag}(\alpha)$  chosen arbitrarily. Thus,  $(\chi_{\alpha,i}^c)_{\alpha,i}$  is a particular Pieri system.

**Lemma 7.7.** The symmetric and exterior characteristic ratios of  $(\chi_{\alpha,i}^c)_{\alpha,i}$  are, respectively, given by

$$\begin{aligned}
 \gamma_{\alpha,i,j}^{c+} &= 1 - u, \\
 \gamma_{\alpha,i,j}^{c-} &= -1 - u
 \end{aligned}
 \tag{7.7}$$

with  $u$  as in (7.6). □

**Proof.** Assume that  $\alpha, \alpha + \epsilon_i, \alpha + \epsilon_j$  are partitions and  $i < j$ . We have the decomposition

$$\mathbb{L}_{\alpha+\epsilon_i+\epsilon_j}^{1\alpha+\epsilon_i} \otimes \mathbb{L}_{\alpha+\epsilon_i}^{1\alpha} \oplus \mathbb{L}_{\alpha+\epsilon_i+\epsilon_j}^{1\alpha+\epsilon_j} \otimes \mathbb{L}_{\alpha+\epsilon_j}^{1\alpha} \cong \mathbb{L}_{\alpha+\epsilon_i+\epsilon_j}^{11\alpha}.$$

To determine the characteristic ratios, we have to compose this with the canonical maps

$$\begin{aligned} \mathbb{L}_{\alpha+\epsilon_i+\epsilon_j}^{11\alpha} &\longrightarrow \mathbb{L}_{\alpha+\epsilon_i+\epsilon_j}^{[2]\alpha}, \\ \mathbb{L}_{\alpha+\epsilon_i+\epsilon_j}^{11\alpha} &\longrightarrow \mathbb{L}_{\alpha+\epsilon_i+\epsilon_j}^{[11]\alpha}. \end{aligned}$$

After left-multiplying everything with an arbitrary  $\mathbb{L}_T$ ,  $T \in \text{diag}(\alpha)$ , we may then use Equations (7.6) to compute the characteristic ratios, taking into account that  $s$  acts by  $\pm 1$  after projecting to the symmetric, respectively, exterior square. It is easy to see that we obtain indeed (7.7).  $\blacksquare$

### Proof of Proposition 7.1.

- (i) It is sufficient to prove this for  $(\chi_{\alpha,i}^c)_{\alpha,i}$  where it follows directly from Lemma 7.7.
- (ii) One easily checks that the ratio  $\gamma^+/\gamma^-$  is the same for every Pieri system. Again the conclusion follows from Lemma 7.7.
- (iii) This follows by writing down the six possible maps  $L^\alpha V \rightarrow V \otimes V \otimes V \otimes L^\alpha V$  that can arise as compositions of maps in the Pieri system and applying the symmetrization  $V \otimes V \otimes V \rightarrow \text{Sym}^3 V$  and anti-symmetrization  $V \otimes V \otimes V \rightarrow \bigwedge^3 V$  to them.
- (iv) Assume that  $(\chi_{\alpha,i}^1)_{\alpha,i}$ ,  $(\chi_{\alpha,i}^2)_{\alpha,i}$  are Pieri systems with the same characteristic ratios. Put  $\mu_{\alpha,i} = \chi_{\alpha,i}^2 / \chi_{\alpha,i}^1$ . Then

$$\frac{\mu_{\alpha+\epsilon_i,j} \cdot \mu_{\alpha,i}}{\mu_{\alpha,j} \cdot \mu_{\alpha+\epsilon_j,i}} = 1. \quad (7.8)$$

We have to find  $c_\alpha \in K^*$  such that

$$\mu_{\alpha,i} = \frac{c_{\alpha+\epsilon_i}}{c_\alpha}. \quad (7.9)$$

The condition (7.8) implies that  $\mu$  represents a cocycle in the cochain complex  $C^\bullet(\mathbb{P}, K^*)$ . Since  $\mathbb{P}$  is contractible by Proposition 7.3,  $\mu$  must be a coboundary. This amounts precisely to  $\mu$  being writable in the form (7.9).

- (v) We will only discuss the symmetric characteristic ratios. The exterior characteristic ratios are entirely similar. Assume we want to construct a Pieri system  $(\chi_{\alpha,i})_{\alpha,i}$  with prescribed  $\gamma_{\alpha,i,j}^+$  satisfying (7.3). Put  $\delta_{\alpha,i,j} = \gamma_{\alpha,i,j}^+ / \gamma_{\alpha,i,j}^{c+}$ . Then  $\delta$  satisfies the equation

$$\frac{\delta_{\alpha+\epsilon_i,jk} \delta_{\alpha,ik} \delta_{\alpha+\epsilon_k,ij}}{\delta_{\alpha,jk} \delta_{\alpha+\epsilon_j,ik} \delta_{\alpha,ij}} = 1. \tag{7.10}$$

We put  $\chi_{\alpha,i} = \mu_{\alpha,i} \chi_{\alpha,i}^c$ . It follows that  $\mu_{\alpha,i}$  must satisfy

$$\frac{\mu_{\alpha+\epsilon_i,j} \cdot \mu_{\alpha,i}}{\mu_{\alpha,j} \cdot \mu_{\alpha+\epsilon_j,i}} = \delta_{\alpha,i,j}. \tag{7.11}$$

The condition (7.10) implies that  $\delta$  represents a cocycle in the cochain complex  $\mathcal{C}^*(\mathbb{P}, K^*)$ . Since  $\mathbb{P}$  is contractible by Proposition 7.3,  $\delta$  must be a coboundary. This amounts precisely to  $\delta$  being writable in the form (7.11). ■

**Remark 7.8.** If we combine Proposition 7.1(iv), Remark 7.2, and Lemma 7.7, we see that the classical Pieri system constructed by Olver is equivalent to  $(\chi_{\alpha,i}^c)_{\alpha,i}$ . Recall that the construction of  $(\chi_{\alpha,i}^c)_{\alpha,i}$  depends on the choice of a basis element in  $\mathbb{L}_{\tau_\alpha}$  for each partition. Since we do not need it we have not verified which basis element one should take to obtain equality rather than equivalence. □

**Remark 7.9.** We extend the definitions of  $\gamma_{\alpha,i,j}^\pm$  to include the possibilities  $i = j$  or  $\alpha_i = \alpha_j$  by

$$\gamma_{\alpha,i,i}^+ = 1 \quad \text{and} \quad \gamma_{\alpha,i,i}^- = 0,$$

while

$$\gamma_{\alpha,i,j}^+ = 0 \quad \text{and} \quad \gamma_{\alpha,i,j}^- = 1$$

if  $\alpha_i = \alpha_j$ . □

We also require basis vectors for the one-dimensional spaces  $\mathbb{L}_{1\alpha-\epsilon_i}^\alpha$ .

**Definition 7.10.** A compatible pair of Pieri systems consists of two families of non-zero equivariant maps

$$\begin{aligned} \chi_{\alpha,i} &: L^{\alpha+\epsilon_i} V \longrightarrow V \otimes L^\alpha V, \\ \varphi_{\alpha,i} &: V \otimes L^{\alpha-\epsilon_i} V \longrightarrow L^\alpha V \end{aligned}$$

such that for each  $\alpha$  the composition

$$L^{\alpha+\epsilon_i} V \xrightarrow{\chi_{\alpha,i}} V \otimes L^\alpha V \xrightarrow{\varphi_{\alpha+\epsilon_i,i}} L^{\alpha+\epsilon_i} V \tag{7.12}$$

is the identity on  $L^{\alpha+\epsilon_i} V$ . □

One can of course make other choices of normalization for the compatibility condition in Definition 7.10. One natural choice is to require that (7.12) is given by multiplication by the scalar  $\dim_{\mathbb{K}} L^\alpha V$ . This complicates the formulas below only slightly.

The relations among the maps in a dual Pieri system are completely determined by the compatibility condition (7.12) and the relations in Proposition 7.1. Let  $\alpha$  be a partition and  $i < j$  such that  $\alpha + \epsilon_i$  and  $\alpha + \epsilon_j$  are both partitions, so we have the picture below.

$$\begin{array}{ccc}
 & V \otimes L^{\alpha+\epsilon_i} V & \\
 1 \otimes \varphi_{\alpha+\epsilon_i,i} \nearrow & & \searrow \varphi_{\alpha+\epsilon_i+\epsilon_j,j} \\
 V \otimes V \otimes L^\alpha V & & L^{\alpha+\epsilon_i+\epsilon_j} \\
 1 \otimes \varphi_{\alpha+\epsilon_j,j} \searrow & & \nearrow \varphi_{\alpha+\epsilon_i+\epsilon_j,i} \\
 & V \otimes L^{\alpha+\epsilon_j} V & 
 \end{array}$$

Set

$$\varphi_{\alpha,i,j} = \varphi_{\alpha+\epsilon_i+\epsilon_j,i} \circ (1 \otimes \varphi_{\alpha+\epsilon_j,j}),$$

$$\varphi_{\alpha,j,i} = \varphi_{\alpha+\epsilon_i+\epsilon_j,j} \circ (1 \otimes \varphi_{\alpha+\epsilon_i,i}).$$

Let  $\varphi_{\alpha,i,j}^+ \in \mathbb{L}_{[2]\alpha}^{\alpha+\epsilon_i+\epsilon_j}$  and  $\varphi_{\alpha,i,j}^- \in \mathbb{L}_{[11]\alpha}^{\alpha+\epsilon_i+\epsilon_j}$  be obtained by symmetrizing, respectively, anti-symmetrizing the input, and define characteristic ratios

$$\delta_{\alpha,i,j}^+ = \frac{\varphi_{\alpha,j,i}^+}{\varphi_{\alpha,i,j}^+}, \quad \delta_{\alpha,i,j}^- = \frac{\varphi_{\alpha,j,i}^-}{\varphi_{\alpha,i,j}^-}.$$

**Proposition 7.11.** Let  $(\chi_{\alpha,i})$  and  $(\varphi_{\alpha,i})$  be a compatible pair of Pieri systems and let  $(\gamma_{\alpha,i,j}^+)$ ,  $(\gamma_{\alpha,i,j}^-)$  be the characteristic ratios for  $(\chi_{\alpha,i})$ . Then

- (i) The characteristic ratios  $\delta_{\alpha,i,j}^\pm$  are finite and non-zero.
- (ii) We have

$$\delta_{\alpha,i,j}^+ = -\gamma_{\alpha,i,j}^- \quad \text{and} \quad \delta_{\alpha,i,j}^- = -\gamma_{\alpha,i,j}^+.$$

In particular,

$$\frac{\delta_{\alpha,i,j}^+}{\delta_{\alpha,i,j}^-} = \frac{\gamma_{\alpha,i,j}^-}{\gamma_{\alpha,i,j}^+} = \frac{u+1}{u-1},$$

where  $u$  is as in (7.2). □



Proposition 7.11 follows immediately from the next lemma, which will also be used in results below. Observe that

$$\begin{aligned}\varphi_{\alpha,i,j}\chi_{\alpha,j,i} &= \varphi_{\alpha+\epsilon_i+\epsilon_j,i}(1 \otimes \varphi_{\alpha+\epsilon_j,j})(1 \otimes \chi_{\alpha,j})\chi_{\alpha+\epsilon_j,i} \\ &= 1\end{aligned}$$

as a map  $L^{\alpha+\epsilon_i+\epsilon_j}V \rightarrow V \otimes V \otimes L^\alpha V \rightarrow L^{\alpha+\epsilon_i+\epsilon_j}V$ . We wish to compute  $\varphi_{\alpha,i,j}^\pm \chi_{\alpha,j,i}^\pm$ , which amounts to understanding the effect of inserting the projectors  $V \otimes V \rightarrow \text{Sym}_2 V \rightarrow V \otimes V$  and  $V \otimes V \rightarrow \wedge^2 V \rightarrow V \otimes V$ .

Note on the other hand that  $\varphi_{\alpha,j,i}\chi_{\alpha,j,i} = 0$ . Indeed,

$$\varphi_{\alpha,j,i}\chi_{\alpha,j,i} = \varphi_{\alpha+\epsilon_i+\epsilon_j,j}(1 \otimes \varphi_{\alpha+\epsilon_i,i})(1 \otimes \chi_{\alpha,j})\chi_{\alpha+\epsilon_j,i}$$

and the middle two maps  $(1 \otimes \varphi_{\alpha+\epsilon_i,i})(1 \otimes \chi_{\alpha,j})$  comprise

$$1 \otimes \varphi_{\alpha+\epsilon_i,i}\chi_{\alpha,j}: V \otimes L^{\alpha+\epsilon_j}V \rightarrow V \otimes V \otimes L^\alpha V \rightarrow V \otimes L^{\alpha+\epsilon_i}V,$$

but there are no non-zero maps  $L^{\alpha+\epsilon_j}V \rightarrow L^{\alpha+\epsilon_i}V$ .

**Lemma 7.12.** We have

$$\varphi_{\alpha,i,j}^+ \chi_{\alpha,j,i}^+ = \frac{-\gamma^+}{\gamma^- - \gamma^+} = \varphi_{\alpha,j,i}^- \chi_{\alpha,i,j}^-, \quad (7.13)$$

$$\varphi_{\alpha,i,j}^- \chi_{\alpha,j,i}^- = \frac{\gamma^-}{\gamma^- - \gamma^+} = \varphi_{\alpha,j,i}^- \chi_{\alpha,i,j}^+, \quad (7.14)$$

where  $\gamma^\pm = \gamma_{\alpha,i,j}^\pm$ . □

**Proof.** Suppress  $\alpha$  from the notation, writing simply  $\varphi_{ij}$ , etc. Applying  $\text{Hom}(L^{\alpha+\epsilon_i+\epsilon_j}V, -)$  to the composition  $L^{\alpha+\epsilon_i+\epsilon_j}V \rightarrow V \otimes V \otimes L^\alpha V \rightarrow L^{\alpha+\epsilon_i+\epsilon_j}V$ , we see that computing  $\varphi_{ij}^\pm \chi_{ji}^\pm$  is the same as finding the image of  $\chi_{ji}^\pm \in \mathbb{L}_{\alpha+\epsilon_i+\epsilon_j}^{11\alpha}$  under the sequence of maps

$$\mathbb{L}_{\alpha+\epsilon_i+\epsilon_j}^{11\alpha} \xrightarrow{(1 \otimes \varphi_{\alpha+\epsilon_j,j})^{\circ-}} \mathbb{L}_{\alpha+\epsilon_i+\epsilon_j}^{1,\alpha+\epsilon_j} \xrightarrow{\varphi_{\alpha+\epsilon_i+\epsilon_j,i}^{\circ-}} \mathbb{L}_{\alpha+\epsilon_i+\epsilon_j}^{\alpha+\epsilon_i+\epsilon_j}.$$

We know that  $\chi_{ji} \mapsto 1$  and that  $\chi_{ij} \mapsto 0$ , so we have only to rewrite the basis  $\{\chi_{ji}^+, \chi_{ji}^-\}$  in terms of the basis  $\{\chi_{ij}, \chi_{ji}\}$ . We have

$$\chi_{ij} = \chi_{ij}^+ + \chi_{ij}^- = \frac{1}{\gamma^+} \chi_{ji}^+ + \frac{1}{\gamma^-} \chi_{ji}^-,$$

$$\chi_{ji} = \chi_{ji}^+ + \chi_{ji}^-.$$

Inverting the  $2 \times 2$  matrix  $\begin{bmatrix} 1/\gamma^+ & 1/\gamma^- \\ 1 & 1 \end{bmatrix}$  gives

$$\begin{aligned} \chi_{ji}^+ &= \frac{\gamma^+\gamma^-}{\gamma^- - \gamma^+} \left( \chi_{ij} - \frac{1}{\gamma^-} \chi_{ji} \right), \\ \chi_{ji}^- &= \frac{\gamma^+\gamma^-}{\gamma^- - \gamma^+} \left( -\chi_{ij} + \frac{1}{\gamma^+} \chi_{ji} \right). \end{aligned} \tag{7.15}$$

Composing with  $\varphi_{ij}$  gives the first equality in each of (7.13) and (7.14). A similar argument establishes the other; alternatively, note that interchanging  $i$  and  $j$  just amounts to replacing  $\gamma^\pm$  by  $1/\gamma^\pm$ . ■

Given a pair of partitions  $\alpha, \gamma$  such that  $\alpha + \epsilon_j = \gamma + \epsilon_i$  we obtain two compositions of Pieri maps

$$\begin{array}{ccc} & V \otimes L^\alpha V & \\ & \swarrow 1 \otimes \chi_{\lambda,i} & \searrow \varphi_{\beta,j} \\ V \otimes V \otimes L^\lambda V & & L^\beta V \\ \downarrow \tau \otimes 1 & & \swarrow \chi_{\gamma,i} \\ V \otimes V \otimes L^\lambda V & & \\ & \searrow 1 \otimes \varphi_{\gamma,j} & \\ & V \otimes L^\gamma V & \end{array} \tag{7.16}$$

where  $\tau : V \otimes V \rightarrow V \otimes V$  denotes the swap,  $\beta = \alpha + \epsilon_j = \gamma + \epsilon_i$  and  $\lambda = \alpha - \epsilon_i = \gamma - \epsilon_j$ . The diagram (7.16) is not commutative; there are non-trivial quadratic relations on the Young quiver relating the two paths.

There are two cases to consider, according to whether  $\alpha = \gamma$ .

Assume first that  $\alpha \neq \gamma$ . Then  $\mathbb{L}_{1\alpha}^{1\gamma}$  is one-dimensional, so we may define another scalar

$$m_{\alpha,i,j} = \frac{(1 \otimes \varphi_{\gamma,j})(\tau \otimes 1)(1 \otimes \chi_{\lambda,i})}{\chi_{\gamma,i}\varphi_{\beta,j}} \tag{7.17}$$

equal to the ratio of the two paths around the diagram above.

In the other case  $\alpha = \gamma$ , the space  $\mathbb{L}_{1\alpha}^{1\alpha}$  is no longer one-dimensional, rather, has dimension equal to the number of ways to add a box to  $\alpha$  to obtain a partition. This is equal to the number of ways to remove a box from  $\alpha$  leaving a dominant weight. Denote this number  $r(\alpha)$ , let  $\Delta_\alpha$  be the set of indices  $i$  such that  $\alpha + \epsilon_i$  is a partition, and let  $\nabla_\alpha$  be the set of indices  $j$  such that  $\alpha - \epsilon_j$  is a dominant weight.

The canonical decompositions

$$\begin{aligned} \mathbb{L}_{1\alpha}^{1\alpha} &= \bigoplus_{i \in \Delta_\alpha} \mathbb{L}_{\alpha+\epsilon_i}^{1\alpha} \otimes \mathbb{L}_{1\alpha}^{\alpha+\epsilon_i} \\ &= \bigoplus_{j \in \nabla_\alpha} \mathbb{L}_{1\alpha-\epsilon_j}^{1\alpha} \otimes \mathbb{L}_{1\alpha}^{1\alpha-\epsilon_j} \end{aligned}$$

equip the  $r(\alpha)$ -dimensional space  $\mathbb{L}_{1\alpha}^{1\alpha}$  with two bases,  $(\chi_{\alpha,i}\varphi_{\alpha+\epsilon_i,i})_{i \in \Delta_\alpha}$  and  $((1 \otimes \varphi_{\alpha,j})(\tau \otimes 1)(1 \otimes \chi_{\alpha-\epsilon_j,j}))_{j \in \nabla_\alpha}$ . We adopt the convention that the former, corresponding to adding, and then removing boxes, is the “natural” basis. Then for each  $j \in \nabla_\alpha$ , there are uniquely defined scalars  $c_{\alpha,i,j}$  such that

$$(1 \otimes \varphi_{\alpha,j})(\tau \otimes 1)(1 \otimes \chi_{\alpha-\epsilon_j,j}) = \sum_{i \in \Delta_\alpha} c_{\alpha,i,j} \chi_{\alpha,i} \varphi_{\alpha+\epsilon_i,i}. \tag{7.18}$$

To compute the scalars  $m_{\alpha,i,j}$  and  $c_{\alpha,i,j}$ , we need the following lemma.

**Lemma 7.13.** We have

$$\begin{aligned} \varphi_{\alpha,j,i}(\tau \otimes 1)\chi_{\alpha,i,j} &= \frac{\gamma^- + \gamma^+}{\gamma^- - \gamma^+}, \\ \varphi_{\alpha,i,j}(\tau \otimes 1)\chi_{\alpha,i,j} &= \frac{-2}{\gamma^- - \gamma^+}, \end{aligned}$$

where as before  $\gamma^\pm = \gamma_{\alpha,i,j}$ . □

**Proof.** As in the proof of Lemma 7.12, we abbreviate  $\chi_{\alpha,i,j}$  as  $\chi_{ij}$  and so on. Also as in that proof, write  $\chi_{ij}^\pm$  in terms of  $\chi_{ij}$  and  $\chi_{ji}$ :

$$\begin{aligned} \chi_{ij}^+ &= \frac{1}{\gamma^- - \gamma^+}(\gamma^- \chi_{ij} - \chi_{ji}), \\ \chi_{ij}^- &= \frac{1}{\gamma^- - \gamma^+}(-\gamma^+ \chi_{ij} + \chi_{ji}). \end{aligned}$$

Since  $\tau$  acts as  $+1$  on  $\text{Sym}_2 V$  and  $-1$  on  $\wedge^2 V$ , we have

$$\begin{aligned} (\tau \otimes 1)\chi_{ij} &= \chi_{ij}^+ - \chi_{ij}^- \\ &= \frac{1}{\gamma^- - \gamma^+}((\gamma^- + \gamma^+)\chi_{ij} - 2\chi_{ji}), \end{aligned}$$

and the desired formulas follow since  $\varphi_{ji}\chi_{ij} = 1$  and  $\varphi_{ij}\chi_{ij} = 0$ . ■

**Proposition 7.14.** Let  $\alpha, \gamma$  be partitions such that  $\alpha + \epsilon_j = \gamma + \epsilon_i$  for some  $i \neq j$ . Set  $\beta = \alpha + \epsilon_j = \gamma + \epsilon_i$  and  $\lambda = \alpha - \epsilon_i = \gamma - \epsilon_j$  as in (7.16). Then

$$m_{\alpha,i,j} = \frac{-2}{\gamma_{\lambda,i,j}^- - \gamma_{\lambda,i,j}^+}. \quad \square$$

**Proof.** Apply  $\text{Hom}(L^\beta V, -)$  to the diagram (7.16) to obtain the pentagon below.

$$\begin{array}{ccc}
 & \mathbb{L}_\beta^{1\alpha} & \\
 (1 \otimes \chi_{\lambda,i}) \circ - & \swarrow & \searrow \varphi_{\beta,j} \circ - \\
 \mathbb{L}_\beta^{11\lambda} & & \mathbb{L}_\beta^\beta \\
 \tau \otimes 1 \downarrow & & \swarrow \chi_{\gamma,i} \circ - \\
 \mathbb{L}_\beta^{11\lambda} & & \mathbb{L}_\beta^{1\gamma} \\
 (1 \otimes \varphi_{\gamma,j}) \circ - & \searrow & 
 \end{array} \tag{7.19}$$

At the top of (7.19), we have the basis element  $\chi_{\alpha,j} \in \mathbb{L}_\beta^{1\alpha}$ . Following this vector down the right-hand side of the diagram, we find at the bottom

$$\chi_{\gamma,i} \varphi_{\beta,j} \chi_{\alpha,j} = \chi_{\gamma,i} \in \mathbb{L}_\beta^{1\gamma}.$$

On the other hand,  $\chi_{\alpha,j}$  maps leftward to

$$(1 \otimes \chi_{\lambda,i}) \chi_{\alpha,j} = \chi_{\lambda,i,j} \in \mathbb{L}_\beta^{11\lambda}.$$

By the definition of  $m_{\alpha,i,j}$ , we have

$$(1 \otimes \varphi_{\gamma,j})(\tau \otimes 1) \chi_{\lambda,i,j} = m_{\alpha,i,j} \chi_{\gamma,i} \in \mathbb{L}_\beta^{1\gamma}.$$

Then composing with  $\varphi_{\beta,i}$  gives

$$\begin{aligned}
 \varphi_{\lambda,i,j}(\tau \otimes 1) \chi_{\lambda,i,j} &= \varphi_{\beta,i}(1 \otimes \varphi_{\gamma,j})(\tau \otimes 1) \chi_{\lambda,i,j} \\
 &= m_{\alpha,i,j} \varphi_{\beta,i} \chi_{\gamma,i} \\
 &= m_{\alpha,i,j}.
 \end{aligned}$$

Now Lemma 7.13 finishes the proof. ■

**Proposition 7.15.** Let  $i, j$  be such that  $\alpha + \epsilon_i$  is a partition and  $\alpha - \epsilon_j$  is a dominant weight. Then

$$c_{\alpha,i,j} = \frac{\gamma_{\alpha-\epsilon_j,i,j}^+ + \gamma_{\alpha-\epsilon_j,i,j}^-}{\gamma_{\alpha-\epsilon_j,i,j}^+ - \gamma_{\alpha-\epsilon_j,i,j}^-}. \quad \square$$

**Proof.** Fix  $k \in \Delta_\alpha$ , and pre-compose Equation (7.18) with  $\chi_{\alpha,k}$  while post-composing with  $\varphi_{\alpha+\epsilon_k,k}$ . On the right-hand side, the result is

$$\sum_{i \in \Delta_\alpha} c_{ij} \varphi_{\alpha+\epsilon_k,k} \chi_{\alpha,i} \varphi_{\alpha+\epsilon_i,i} \chi_{\alpha,k}.$$

For  $i \neq k$ , note that  $\varphi_{\alpha+\epsilon_k,k} \chi_{\alpha,i} : L^{\alpha+\epsilon_i} V \rightarrow V \otimes L^\alpha V \rightarrow L^{\alpha+\epsilon_k}$  is the zero map. Hence, the entirety of the right-hand side is

$$c_{kj} \varphi_{\alpha+\epsilon_k,k} \chi_{\alpha,k} \varphi_{\alpha+\epsilon_k,k} \chi_{\alpha,k} = c_{kj}.$$

On the other side, we obtain

$$\begin{aligned} \varphi_{\alpha+\epsilon_k,k} (1 \otimes \varphi_{\alpha,j}) (\tau \otimes 1) (1 \otimes \chi_{\alpha-\epsilon_j,j}) \chi_{\alpha,k} &= \varphi_{\alpha-\epsilon_j,k,j} (\tau \otimes 1) \chi_{\alpha-\epsilon_j,j,k} \\ &= \frac{\gamma_{\alpha-\epsilon_j,j,k}^- + \gamma_{\alpha-\epsilon_j,j,k}^+}{\gamma_{\alpha-\epsilon_j,j,k}^- - \gamma_{\alpha-\epsilon_j,j,k}^+} \end{aligned}$$

by Lemma 7.13. To get the result in terms of  $\gamma_{\alpha-\epsilon_j,k,j}^\pm$ , replace each  $\gamma$  appearing by its reciprocal. ■

**Corollary 7.16.** For any Pieri system, any  $\alpha$ , and any  $i, j$ , we have  $c_{\alpha,i,j} \neq 0$ . □

**Proof.** If  $\gamma_{\alpha-\epsilon_j,i,j} = -\gamma_{\alpha-\epsilon_j,i,j}$ , then  $1 - u = 1 + u$ , so that  $u = 0$ , which is impossible by the definition of  $u$ . ■

This finishes the proof of Lemma 6.7 and therefore Theorem 6.9.

**Remark 7.17.** If the given Pieri system  $(\chi_{\alpha,i})$  is equivalent to the classical system, so that  $\gamma_{\alpha,i,j}^+ = 1 - u$  and  $\gamma_{\alpha,i,j}^- = -(1 + u)$  with

$$u = \frac{1}{(i - \alpha_i - 1) - (j - \alpha_j - 1)},$$

then the other scalars can also be written in terms of  $u$ :

$$\delta_{\alpha,i,j}^+ = u - 1; \quad \delta_{\alpha,i,j}^- = u + 1;$$

$$m_{\alpha,i,j} = 1;$$

and

$$c_{\alpha,i,j} = \frac{u}{u+1}. \quad \square$$

We finish the section by making explicit the relations on the Young quiver (Definition 6.5).

**Theorem 7.18.** Let  $(\chi_{\alpha,i}), (\varphi_{\alpha,i})$  be a choice of a compatible pair of Pieri systems, and let  $\gamma_{\alpha,i,j}^{\pm}, \delta_{\alpha,i,j}^{\pm}$  be the characteristic ratios for  $(\chi_{\alpha,i}), (\varphi_{\alpha,i})$ , respectively. Let  $\alpha, \gamma \in B_{l,m-l}$ . The relations on the truncated Young quiver between the vertices labeled  $\alpha$  and  $\gamma$  are the kernels of the following linear maps.

- (i) If  $\gamma$  is obtained by adding two boxes to  $\alpha$  in rows  $i < j$ , the map  $(F^{\vee} \otimes F^{\vee})^{\oplus 2} \rightarrow F^{\vee} \otimes F^{\vee}$  defined by

$$(\lambda_1 \otimes \lambda_2, \lambda'_1 \otimes \lambda'_2) \mapsto \lambda_1 \otimes \lambda_2 + \frac{1}{2}[(\gamma_{\alpha,i,j}^+ + \gamma_{\alpha,i,j}^-)\lambda'_1 \otimes \lambda'_2 + (\gamma_{\alpha,i,j}^+ - \gamma_{\alpha,i,j}^-)\lambda'_2 \otimes \lambda'_1].$$

- (ii) If  $\gamma$  is obtained by removing two boxes from  $\alpha$  in rows  $i < j$ , the map  $(G \otimes G)^{\oplus 2} \rightarrow G \otimes G$  defined by

$$\begin{aligned} (g_1 \otimes g_2, g'_1 \otimes g'_2) &\mapsto g_1 \otimes g_2 + \frac{1}{2}[(\delta_{\alpha,i,j}^+ + \delta_{\alpha,i,j}^-)g'_1 \otimes g'_2 + (\delta_{\alpha,i,j}^+ - \delta_{\alpha,i,j}^-)g'_2 \otimes g'_1] \\ &= g_1 \otimes g_2 - \frac{1}{2}[(\gamma_{\alpha,i,j}^+ + \gamma_{\alpha,i,j}^-)g'_1 \otimes g'_2 + (\gamma_{\alpha,i,j}^+ - \gamma_{\alpha,i,j}^-)g'_2 \otimes g'_1]. \end{aligned}$$

- (iii) If  $\gamma$  is obtained by moving a box in  $\alpha$  from row  $i$  to row  $j > i$ , the map  $(F^{\vee} \otimes G)^{\oplus 2} \rightarrow F^{\vee} \otimes G$  defined by

$$\begin{aligned} (\lambda \otimes g, \lambda' \otimes g') &\mapsto \lambda \otimes g + m_{\alpha,i,j} \lambda' \otimes g' \\ &= \lambda \otimes g + \frac{2}{\gamma_{\alpha,i,j}^+ - \gamma_{\alpha,i,j}^-} \lambda' \otimes g'. \end{aligned}$$

- (iv) If  $\gamma = \alpha$ , the map  $(F^{\vee} \otimes G)^{\oplus(t(\alpha)+r(\alpha)-1)} \rightarrow (F^{\vee} \otimes G)^{\oplus(r(\alpha))}$  defined by

$$\begin{aligned} ((\lambda_i \otimes g_i)_{i \in \Delta'_\alpha}, (\lambda'_j \otimes g'_j)_{j \in \nabla'_\alpha}) &\mapsto \left( \lambda_i \otimes g_i + \sum_{j \in \nabla'_\alpha} c_{\alpha,i,j} \lambda'_j \otimes g'_j \right)_{i \in \Delta'_\alpha} \\ &= \left( \lambda_i \otimes g_i + \sum_{j \in \nabla'_\alpha} \frac{\gamma_{\alpha-\epsilon_j,i,j}^+ + \gamma_{\alpha-\epsilon_j,i,j}^-}{\gamma_{\alpha-\epsilon_j,i,j}^+ - \gamma_{\alpha-\epsilon_j,i,j}^-} \lambda'_j \otimes g'_j \right)_{i \in \Delta'_\alpha}, \end{aligned}$$

where  $\Delta'_\alpha$  is the set of indices  $i$  such that  $\alpha + \epsilon_i \in B_{l,m-l}$ ,  $\nabla'_\alpha$  is similarly the set of indices  $j$  with  $\alpha - \epsilon_j \in B_{l,m-l}$ ,  $t(\alpha)$  is the number of ways to add a box

to  $\alpha$  without making any row longer than  $m - l$ , and  $r(\alpha)$  is the total number of ways to add a box to  $\alpha$ . □

### 8 Example: Grass(2, 4)

Let us compute the quiver and some of the relations for the first non-trivial example,  $(m, n, l) = (4, 4, 2)$ . As a matter of notational convenience, we denote the vertices  $\mathcal{N}_\alpha = p^* L^\alpha \mathcal{Q}$  of the quiver by the corresponding Young diagrams. We live inside the box  $B_{2,2}$ , and therefore have the quiver below.

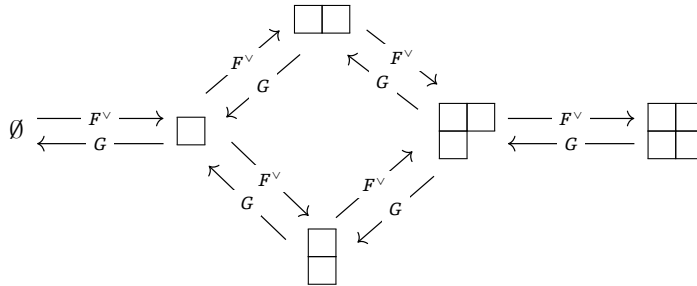

In this picture, each arrow  $F^\vee: \alpha \rightarrow \alpha + \epsilon_i$  represents  $\mathbb{L}_{1^\alpha}^{\alpha + \epsilon_i} \otimes F^\vee$ , while each  $G: \alpha + \epsilon_i \rightarrow \alpha$  represents  $\mathbb{L}_{1^{\alpha + \epsilon_i}}^\alpha \otimes G$ . The action of the linear maps on the bundles  $\mathcal{N}_\alpha$  is via the natural maps (6.1).

Even more explicitly, if we fix bases  $\{\lambda_1, \dots, \lambda_4\}$  and  $\{g_1, \dots, g_4\}$  for  $F^\vee$  and  $G$ , then each such arrow stands for four arrows labeled by  $\varphi_{\alpha + \epsilon_i, i} \otimes \lambda_k$ , respectively,  $\chi_{\alpha, i} \otimes g_k$ , where  $(\chi_{\alpha, i})$  and  $(\varphi_{\alpha, i})$  is a chosen pair of compatible Pieri systems.

Let us write down a particular compatible pair of Pieri systems. In fact, it is just as easy to write down a pair of Pieri systems for all partitions  $\alpha = (p, q)$  with at most two rows. The corresponding Schur functor  $L^{(p,q)} V$  is a quotient of  $(\wedge^2 V)^{\otimes q} \otimes \text{Sym}_{p-q} V$ , modulo certain exchange-type relations. For example, in the case of  $\begin{smallmatrix} \square & \square \\ \square & \square \end{smallmatrix}$ , we have

$$u \wedge v \otimes w + v \wedge w \otimes u + w \wedge u \otimes v = 0.$$

We denote a general element of  $L^{(p,q)} V$  by

$$\prod_{k=1}^q (u_k \wedge v_k) \otimes \underline{x},$$

where  $\underline{x} = x_1 \cdots x_{p-q} \in \text{Sym}_{p-q} V$ . Further denote by  $\underline{x}_i$  the product  $x_1 \cdots \hat{x}_i \cdots x_{p-q}$  with  $x_i$  deleted.

Define  $\chi_{(p,q),1}: L^{(p+1,q)}V \longrightarrow V \otimes L^{(p,q)}V$  by

$$\begin{aligned} \prod_{k=1}^q (u_k \wedge v_k) \otimes \underline{x} \mapsto & \sum_{i=1}^{p-q+1} x_i \otimes \prod_{k=1}^q (u_k \wedge v_k) \otimes \underline{x}_i \\ & + \frac{1}{p-q+2} \sum_{j=1}^q \left( u_j \otimes x_i \wedge v_j \otimes \prod_{k \neq j} (u_k \wedge v_k) \otimes \underline{x}_i \right. \\ & \left. + v_j \otimes u_j \wedge x_i \otimes \prod_{k \neq j} (u_k \wedge v_k) \otimes \underline{x}_i \right) \end{aligned}$$

and  $\chi_{(p,q),2}: L^{(p,q+1)}V \longrightarrow V \otimes L^{(p,q)}V$  by

$$\prod_{k=1}^{q+1} (u_k \wedge v_k) \otimes \underline{x} \mapsto \sum_{i=1}^{q+1} \left( u_i \otimes \prod_{k \neq i} (u_k \wedge v_k) \otimes v_i \underline{x} - v_i \otimes \prod_{k \neq i} (u_k \wedge v_k) \otimes u_i \underline{x} \right).$$

We also define the dual Pieri maps  $\varphi_{(p+1,q),1}: V \otimes L^{(p,q)}V \longrightarrow L^{(p+1,q)}$  by

$$w \otimes \prod_{k=1}^q (u_k \wedge v_k) \otimes \underline{x} \mapsto \frac{(p-q+2)}{(p+2)(p-q+1)} \prod_{k=1}^q (u_k \wedge v_k) \otimes w \underline{x}$$

and  $\varphi_{(p,q+1),2}: V \otimes L^{(p,q)}V \longrightarrow L^{(p,q+1)}V$  by

$$w \otimes \prod_{k=1}^q (u_k \wedge v_k) \otimes \underline{x} \mapsto \frac{1}{(q+1)(p-q+1)} \sum_{i=1}^{p-q} w \wedge x_i \otimes \prod_{k=1}^q (u_k \wedge v_k) \otimes \underline{x}_i.$$

It is a soothing combinatorial exercise to prove that each of these maps is well defined and that  $\varphi_{(p,q)+\epsilon_i,i}$  is a left inverse for  $\chi_{\alpha,i}$ .

We point out that these are essentially the classical Pieri systems of Olver, as we shall confirm below (at least up to equivalence) by computing the characteristic ratios.

For the six partitions of interest, the formulas simplify:

$$\chi_{\emptyset,1}: \square \longrightarrow V \otimes \emptyset, \quad u \mapsto u \otimes 1,$$

$$\chi_{\square,1}: \square \square \longrightarrow V \otimes \square, \quad uw \mapsto u \otimes v + v \otimes u,$$

$$\chi_{\square,2}: \begin{array}{|c|} \hline \square \\ \hline \end{array} \longrightarrow V \otimes \square, \quad u \wedge v \mapsto u \otimes v - v \otimes u,$$

$$\chi_{\begin{array}{|c|} \hline \square \\ \hline \square \\ \hline \end{array},1}: \begin{array}{|c|} \hline \square \\ \hline \square \\ \hline \end{array} \longrightarrow V \otimes \begin{array}{|c|} \hline \square \\ \hline \end{array}, \quad u \wedge v \otimes w \mapsto w \otimes u \wedge v + \frac{1}{2}(u \otimes w \wedge v + v \otimes u \wedge w),$$

$$\chi_{\begin{array}{|c|} \hline \square \\ \hline \square \\ \hline \square \\ \hline \end{array},2}: \begin{array}{|c|} \hline \square \\ \hline \square \\ \hline \square \\ \hline \end{array} \longrightarrow V \otimes \square, \quad u \wedge v \otimes w \mapsto u \otimes vw - v \otimes uw,$$



$$\chi_{\square,2}^{\square}: \square \rightarrow V \otimes \square, \quad t \wedge u \otimes v \wedge w \mapsto t \otimes v \wedge w \otimes u - u \otimes v \wedge w \otimes t$$

$$+ v \otimes t \wedge u \otimes w - w \otimes t \wedge u \otimes v,$$

$$\varphi_{\square,1}: V \otimes \emptyset \rightarrow \square, \quad u \otimes 1 \mapsto u,$$

$$\varphi_{\square,1}: V \otimes \square \rightarrow \square, \quad u \otimes v \mapsto \frac{1}{2}uw,$$

$$\varphi_{\square,2}: V \otimes \square \rightarrow \square, \quad u \otimes v \mapsto \frac{1}{2}u \wedge v,$$

$$\varphi_{\square,1}: V \otimes \square \rightarrow \square, \quad u \otimes v \wedge w \mapsto \frac{2}{3}v \wedge w \otimes u,$$

$$\varphi_{\square,2}: V \otimes \square \rightarrow \square, \quad u \otimes vw \mapsto \frac{1}{3}(u \wedge v \otimes w + u \wedge w \otimes v),$$

$$\varphi_{\square,2}: V \otimes \square \rightarrow \square, \quad u \otimes v \wedge w \otimes t \mapsto \frac{1}{4}u \wedge t \otimes v \wedge w.$$

Let us verify the relations across the central diamond.

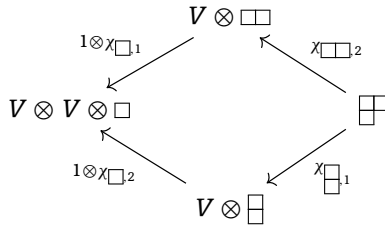

One computes the characteristic ratios

$$\gamma_{\square,1,2}^+ = \frac{\chi_{\square,2,1}^+}{\chi_{\square,1,2}^+} = \frac{3}{2} \quad \text{and} \quad \gamma_{\square,1,2}^- = \frac{\chi_{\square,2,1}^-}{\chi_{\square,1,2}^-} = -\frac{1}{2}.$$

Observe that

$$\gamma_{\square,1,2}^+ = 1 - u \quad \text{and} \quad \gamma_{\square,1,2}^- = -1 - u,$$

where

$$u = \frac{1}{(1-p-1) - (2-q-1)} = \frac{-1}{p-q+1} = -\frac{1}{2},$$

are the characteristic ratios of Olver's classical Pieri system, cf. Lemma 7.7 and Remark 7.8. One checks laboriously that the same holds true for all the  $(\chi_{(p,q),i})$  defined above. In particular, we verify

$$\frac{\gamma_{\square,1,2}^+}{\gamma_{\square,1,2}^-} = \frac{3/2}{-1/2} = -3 = \frac{u-1}{u+1}.$$

The relation in the reverse direction across the central diamond is also easy to compute.

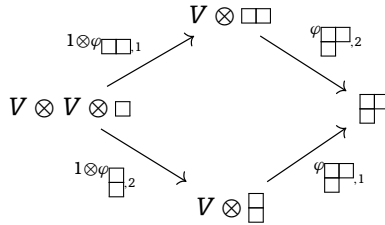

One finds

$$\delta_{\square,1,2}^+ = \frac{\varphi_{\square,2,1}^+}{\varphi_{\square,1,2}^+} = \frac{1}{2}$$

and

$$\delta_{\square,1,2}^- = \frac{\varphi_{\square,2,1}^-}{\varphi_{\square,1,2}^-} = -\frac{3}{2}$$

in accordance with Proposition 7.11.

We can also compute the relation corresponding to moving a box downward in  $\square\square$  to obtain  $\square$ , finding

$$m_{\square,1,2} = \frac{(1 \otimes \varphi_{\square,2}) (\tau \otimes 1) (1 \otimes \chi_{\square,1})}{\chi_{\square,1} \varphi_{\square,2}} = \frac{1/2}{1/2} = 1.$$

Of course, this matches Proposition 7.14 and Remark 7.17:

$$m_{\square,1,2} = \frac{-2}{\gamma_{\square,1,2}^- - \gamma_{\square,1,2}^+} = \frac{-2}{-1/2 - 3/2} = 1.$$

Finally, in order to compute the relation at a single vertex, say  $\alpha = \square$ , we write all of the 2-cycles leaving  $\alpha$  via  $\mathbb{L}_{1\alpha}^{11\alpha-\epsilon_j} \otimes G$  (removing a box) in terms of the basis of  $\mathbb{L}_{1\alpha}^{1\alpha}$  given by those cycles leaving via  $\mathbb{L}_{1\alpha}^{\alpha+\epsilon_i}$  (adding a box). We have  $\Delta_\alpha = \{1, 2\}$  and

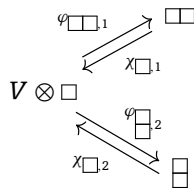

$$\chi_{\square,1} \varphi_{\square,1}: \quad u \otimes v \mapsto \frac{1}{2} u v \mapsto \frac{1}{2} (u \otimes v + v \otimes u),$$

$$\chi_{\square,2} \varphi_{\square,2}: \quad u \otimes v \mapsto \frac{1}{2} u \wedge v \mapsto \frac{1}{2} (u \otimes v - v \otimes u).$$

In the other direction, we have

$$(1 \otimes \varphi_{\square_1})(\tau \otimes 1)(1 \otimes \chi_{\emptyset,1}): \quad \mathbf{u} \otimes v \mapsto \mathbf{u} \otimes v \otimes 1 \mapsto v \otimes \mathbf{u} \otimes 1 \mapsto v \otimes \mathbf{u}.$$

Thus,

$$(1 \otimes \varphi_{\square_1})(\tau \otimes 1)(1 \otimes \chi_{\emptyset,1}) = (\chi_{\square_1} \varphi_{\square_1}) - (\chi_{\square_2} \circ \varphi_{\square_2})$$

and

$$c_{\square_1,1} = 1 \quad \text{while} \quad c_{\square_2,1} = -1.$$

This is a somewhat trivial example, coming down to  $\gamma_{\emptyset,1,1}^+ = 1$ ,  $\gamma_{\emptyset,1,1}^- = 0$ ,  $\gamma_{\emptyset,1,2}^+ = 0$ , and  $\gamma_{\emptyset,1,2}^- = 1$ .

The action of the quiver on the bundles  $\mathcal{N}_\alpha$  is defined in terms of the adjoints  $\chi_{\alpha,i}^\#: V^\vee \otimes L^{\alpha+\epsilon_i} V \longrightarrow L^\alpha V$  of the Pieri maps  $\chi_{\alpha,i}: L^{\alpha+\epsilon_i} V \longrightarrow V \otimes L^\alpha V$  defined above. We denote the trace pairing  $\text{Tr}: V^\vee \otimes V \longrightarrow K$  by  $\lambda \otimes v \mapsto \lambda(v)$ .

$$\chi_{\emptyset,1}^\#: V^\vee \otimes \square \longrightarrow \emptyset, \quad \lambda \otimes \mathbf{u} \mapsto \lambda(\mathbf{u}),$$

$$\chi_{\square_1}^\#: V^\vee \otimes \square \longrightarrow \square, \quad \lambda \otimes \mathbf{u} \mapsto \lambda(\mathbf{u})v + \lambda(v)\mathbf{u},$$

$$\chi_{\square_2}^\#: V^\vee \otimes \square \longrightarrow \square, \quad \lambda \otimes \mathbf{u} \wedge v \mapsto \lambda(\mathbf{u})v - \lambda(v)\mathbf{u},$$

$$\chi_{\square_1}^\#: V^\vee \otimes \square \longrightarrow \square, \quad \lambda \otimes \mathbf{u} \wedge v \otimes w \mapsto \lambda(w)\mathbf{u} \wedge v$$

$$+ \frac{1}{2}(\lambda(\mathbf{u})w \wedge v + \lambda(v)\mathbf{u} \wedge w),$$

$$\chi_{\square_2}^\#: V^\vee \otimes \square \longrightarrow \square, \quad \lambda \otimes \mathbf{u} \wedge v \otimes w \mapsto \lambda(\mathbf{u})vw - \lambda(v)w\mathbf{u},$$

$$\chi_{\square_2}^\#: V^\vee \otimes \square \longrightarrow \square, \quad \lambda \otimes t \wedge \mathbf{u} \otimes v \wedge w \mapsto \lambda(t)v \wedge w \otimes \mathbf{u} - \lambda(\mathbf{u})v \wedge w \otimes t$$

$$+ \lambda(v)t \wedge \mathbf{u} \otimes w - \lambda(w)t \wedge \mathbf{u} \otimes v.$$

The characteristic ratios of these adjoint maps are equal to those of the originals.

Now the relations on the quiver are clear. For instance, between  $\emptyset$  and  $\square$  we have  $\bigwedge^2 F^\vee = 0$ , that is,

$$(\varphi_{\square_1} \otimes \lambda_k)(\varphi_{\square_1} \otimes \lambda_l) - (\varphi_{\square_1} \otimes \lambda_l)(\varphi_{\square_1} \otimes \lambda_k) = 0$$

for all  $k, l = 1, \dots, 4$ , or more compactly  $\lambda_k \lambda_l = \lambda_l \lambda_k$ .

Across the central diamond, we have relations defined by the kernel of

$$\begin{aligned} (\lambda_r \otimes \lambda_s, \lambda_t \otimes \lambda_u) &\mapsto \lambda_r \otimes \lambda_s + \frac{1}{2}[(\gamma_{\alpha,i,j}^+ + \gamma_{\alpha,i,j}^-)\lambda_t \otimes \lambda_u + (\gamma_{\alpha,i,j}^+ - \gamma_{\alpha,i,j}^-)\lambda_u \otimes \lambda_t] \\ &= \lambda_r \otimes \lambda_s + \frac{1}{2}[(\frac{3}{2} - \frac{1}{2})\lambda_t \otimes \lambda_u + (\frac{3}{2} + \frac{1}{2})\lambda_u \otimes \lambda_t] \\ &= \lambda_r \otimes \lambda_s + \frac{1}{2}\lambda_t \otimes \lambda_u + \lambda_u \otimes \lambda_t. \end{aligned}$$

This kernel is of course isomorphic to  $F^\vee \otimes F^\vee$ . Similarly, from  $\square$  to  $\square$  we have relations defined by the kernel of

$$(g_r \otimes g_s, g_t \otimes g_u) \mapsto g_r \otimes g_s - \frac{1}{2}g_t \otimes g_u - g_u \otimes g_t.$$

Since  $m_{\square,1,2} = 1$  (see Remark 7.17), the vertical relation across the central diamond is just the commutativity relation.

Finally, at the vertex  $\square$  we have relations defined by the kernel of

$$(\lambda_a \otimes g_b, \lambda_c \otimes g_d, \lambda_e \otimes g_f) \mapsto (\lambda_a \otimes g_b + \lambda_e \otimes g_f, \lambda_c \otimes g_d - \lambda_e \otimes g_f, \lambda_a \otimes g_b + 3\lambda_c \otimes g_d).$$

## Funding

The first author was partly supported by NSERC grant 3-642-114-80. The second author was partly supported by National Science Foundation grant DMS 0902119 and National Security Agency grant H98230-05-1-0032. The third author is director of research at the FWO. Part of this research was supported through the program ‘‘Research in Pairs’’ by the Mathematisches Forschungsinstitut Oberwolfach in 2012, and part was carried out at the Mathematical Sciences Research Institute in 2013 with the support of the National Science Foundation under Grant No. 0932078 000. We thank both institutes for their hospitality.

## Acknowledgements

We are grateful to Vincent Franjou, Catharina Stroppel, and Antoine Touz e for help with references, and to Jerzy Weyman, Steven V Sam, and Gufang Zhao for interesting conversations.

## Appendix. The Quiverized Clifford Algebra

We offer here an alternative approach to the proof of Theorem B, which is conceptually closer to the spirit of [5], but is a bit too cumbersome for explicit examples due to the multiple identifications involved.

**Quiverization**

Let  $\Gamma$  be a linearly reductive algebraic group over an arbitrary field  $K$  and let  $\check{\Gamma}$  be the set of characters of  $\Gamma$ . If  $\alpha \in \check{\Gamma}$ , then we denote its corresponding irreducible representation by  $\mathbb{S}^\alpha$ . The character belonging to the dual representation  $(\mathbb{S}^\alpha)^\vee = \text{Hom}_\Gamma(\mathbb{S}^\alpha, K)$  will be denoted by  $\alpha^*$ . Write  $\emptyset$  for the character of the trivial representation.

Let  $\text{mod}(\Gamma)$  be the category of rational representations of  $\Gamma$ , and let  $\text{mod}^\circ(\Gamma)$  be the category of collections of vector spaces  $V = (V_\alpha)_{\alpha \in \check{\Gamma}}$ . We have functors

$$Q^\circ: \text{mod}(\Gamma) \longrightarrow \text{mod}^\circ(\Gamma), \quad V \mapsto (\text{Hom}_\Gamma(\mathbb{S}^\alpha, V))_{\alpha \in \check{\Gamma}},$$

$$R^\circ: \text{mod}^\circ(\Gamma) \longrightarrow \text{mod}(\Gamma), \quad V \mapsto \bigoplus_{\beta \in \check{\Gamma}} V_\beta \otimes \mathbb{S}^\beta.$$

The following lemma just expresses the fact that  $\text{mod}(\Gamma)$  is a semisimple category.

**Lemma A.1.** The functors  $Q^\circ$  and  $R^\circ$  define inverse equivalences of categories. □

Unfortunately, it is not immediately obvious what  $Q^\circ$  does to the monoidal structure on  $\text{mod}(\Gamma)$ . Therefore, we introduce another monoidal category  $\text{mod}^1(\Gamma)$  which consists of collections of vector spaces  $\mathbb{V} = (V_\beta)_{\alpha, \beta \in \check{\Gamma}}$  with tensor product defined as in matrix multiplication:

$$(\mathbb{V} \otimes \mathbb{W})_\gamma^\alpha = \bigoplus_{\beta \in \check{\Gamma}} V_\beta^\alpha \otimes W_\gamma^\beta.$$

Furthermore,  $\text{mod}^1(\Gamma)$  acts on  $\text{mod}^\circ(\Gamma)$  by

$$(\mathbb{V} \otimes W)_\alpha = \bigoplus_{\beta \in \check{\Gamma}} V_\alpha^\beta \otimes W_\beta.$$

**Lemma A.2.** There is a fully faithful monoidal functor

$$Q: \text{mod}(\Gamma) \longrightarrow \text{mod}^1(\Gamma), \quad V \mapsto (\text{Hom}_\Gamma(\mathbb{S}^\beta, \mathbb{S}^\alpha \otimes V))_\beta^\alpha,$$

which is also compatible with the left actions of  $\text{mod}(\Gamma)$  on itself and of  $\text{mod}^1(\Gamma)$  on  $\text{mod}^\circ(\Gamma)$ . □

**Proof.** That  $Q$  is fully faithful follows from the fact that it has a left inverse

$$R: \text{mod}^1(\Gamma) \longrightarrow \text{mod}(\Gamma), \quad \mathbb{V} \mapsto \bigoplus_{\beta \in \check{\Gamma}} \mathbb{V}_\beta^\emptyset \otimes \mathbb{S}^\beta.$$

That  $Q$  is compatible with tensor product is a straightforward verification. ■

From this, we easily obtain the following.

**Lemma A.3.** If  $C$  is an algebra object in  $\text{mod}(\Gamma)$ , then  $Q(C)$  is an algebra object in  $\text{mod}^1(\Gamma)$ , and if  $C$  is given by generators and relations as a quotient of a tensor algebra, say,  $C = TV/I$  for  $\Gamma$ -representations  $V$  and  $I$ , then

$$Q(C) = T(Q(V))/(Q(I)).$$

Furthermore,  $Q^\circ$  defines an equivalence between the category  $\text{mod}_\Gamma(C)$  of left  $\Gamma$ -equivariant  $C$ -modules and the category  $\text{mod}^\circ(Q(C))$  of left  $Q(C)$ -modules in  $\text{mod}^\circ(\Gamma)$ .  $\square$

Here we understand  $T(Q(V))$  to be the tensor algebra defined in terms of the natural monoidal structure on  $\text{mod}^1(\Gamma)$ .

If  $D$  is a subset of  $\check{\Gamma}$ , then we denote by  $\text{mod}_D(C)$  the  $\Gamma$ -equivariant  $C$ -modules whose characters lie in  $D$ . Also write

$$Q_D(C) = Q(C)/(e_\alpha)_{\alpha \notin D}$$

for the quotient of  $Q(C)$  by the idempotents  $e_\alpha$  corresponding to characters  $\alpha$  not in  $D$ .

**Lemma A.4.** Let  $C$  be an algebra object in  $\text{mod}(\Gamma)$ . The equivalence  $Q^\circ: \text{mod}_\Gamma(C) \rightarrow \text{mod}^\circ(Q(C))$  restricts to an equivalence between  $\text{mod}_D(C)$  and  $\text{mod}(Q_D(C))$ .  $\square$

We define the indicator spaces  $\mathbb{L}$  in this more general setting analogously to Definition 6.1.

**Definition A.5.** Let  $\alpha_1, \dots, \alpha_n, \beta \in \check{\Gamma}$ , and set

$$\mathbb{L}_\beta^{\alpha_1 \cdots \alpha_n} = \text{Hom}_\Gamma(\mathbb{S}^\beta, \mathbb{S}^{\alpha_1} \otimes \cdots \otimes \mathbb{S}^{\alpha_n}). \quad \square$$

Obvious analogs of the properties in Proposition 6.2 hold in this setting.

**Proposition A.6.** Let  $V = (V_\alpha)_\alpha$  and  $W = (W_\alpha)_\alpha \in \text{mod}^\circ(\Gamma)$ . Then

$$Q(R^\circ(V))_\gamma^\beta = Q\left(\bigoplus_\alpha V_\alpha \otimes \mathbb{S}^\alpha\right)_\gamma^\beta \cong \bigoplus_\alpha V_\alpha \otimes \mathbb{L}_\gamma^{\alpha\beta}$$

and

$$Q(V \otimes W)_\gamma^\beta = \bigoplus_{\alpha_1, \alpha_2} V_{\alpha_1} \otimes W_{\alpha_2} \otimes \mathbb{L}_\gamma^{\alpha_1 \alpha_2 \beta}. \quad \square$$

The canonical isomorphism  $Q(V \otimes W) \cong Q(V) \otimes Q(W)$  is given by

$$\begin{aligned} \bigoplus_{\alpha_1, \alpha_2} V_{\alpha_1} \otimes W_{\alpha_2} \otimes \mathbb{L}_\gamma^{\alpha_1 \alpha_2 \beta} &\cong Q(V \otimes W)_\gamma^\beta \\ &\cong \bigoplus_{\delta} Q(V)_\delta^\beta \otimes Q(W)_\gamma^\delta \\ &\cong \bigoplus_{\delta, \alpha_1, \alpha_2} V_{\alpha_1} \otimes \mathbb{L}_\delta^{\alpha_1 \beta} \otimes W_{\alpha_2} \otimes \mathbb{L}_\gamma^{\alpha_2 \delta} \end{aligned}$$

combined with the isomorphism

$$\mathbb{L}_\gamma^{\alpha_1 \alpha_2 \beta} \cong \bigoplus_{\delta} \mathbb{L}_\gamma^{\alpha_2 \delta} \otimes \mathbb{L}_\delta^{\alpha_1 \beta}$$

from Proposition 6.2(iii).

### The Clifford algebra

We want to use the quiverization recipe above applied to the general linear group, so from now on we assume that  $K$  is a field of characteristic zero.

We fix an arbitrary  $(m - l)$ -dimensional vector space  $U$  and set  $\tilde{F} = F \otimes U^\vee$ ,  $\tilde{G} = G \otimes U^\vee$ . There is a natural pairing

$$\langle -, - \rangle: \tilde{F}^\vee \times \tilde{G} \longrightarrow S,$$

which is just the inclusion  $F^\vee \otimes G \longrightarrow S$  combined with the canonical pairing  $U \otimes U^\vee \longrightarrow K$ . We extend this pairing to a symmetric bilinear form on  $(\tilde{F}^\vee \oplus \tilde{G}) \times (\tilde{F}^\vee \oplus \tilde{G})$  and thence to a quadratic form  $b: \tilde{F}^\vee \oplus \tilde{G} \longrightarrow S$ .

We let  $C$  be the associated Clifford algebra of  $b$  over  $S$ . For a concrete description, choose ordered bases  $\{\lambda_1, \dots, \lambda_m\}$ ,  $\{g_1, \dots, g_n\}$ , and  $\{u_1, \dots, u_{m-l}\}$  for  $F^\vee$ ,  $G$ , and  $U$ , respectively, and let  $\{u_1^*, \dots, u_{m-l}^*\}$  denote the dual basis for  $U^\vee$ . Then  $C$  is the  $S$ -algebra generated by  $\{\lambda_i \otimes u_a\}_{i,a}$  and  $\{g_j \otimes u_b^*\}_{j,b}$  subject to the relations

$$(\lambda_i \otimes u_a)(\lambda_j \otimes u_b) + (\lambda_j \otimes u_b)(\lambda_i \otimes u_a) = 0 = (\lambda_i \otimes u_a)^2 \quad \text{for } i, j = 1, \dots, m;$$

$$(g_i \otimes u_a^*)(g_j \otimes u_b^*) + (g_j \otimes u_b^*)(g_i \otimes u_a^*) = 0 = (g_i \otimes u_a^*)^2 \quad \text{for } i, j = 1, \dots, n; \text{ and}$$

$$(\lambda_i \otimes u_a)(g_j \otimes u_b^*) + (g_j \otimes u_b^*)(\lambda_i \otimes u_a) = \delta_{ab} x_{ij} \quad \text{for } i = 1, \dots, m, j = 1, \dots, n$$

for all  $a, b = 1, \dots, m - l$ .

Recall that  $B_{l, m-l}$  denotes the set of partitions having at most  $l$  rows and at most  $m - l$  columns, which we now think of as representing characters for  $\text{GL}(U) \cong \text{GL}(m - l)$

via the identification  $\alpha \leftrightarrow L^{\alpha'} U$  (note the transpose!), where  $L^{\alpha'}$  is the Schur functor for the weight  $\alpha'$ .

**Definition A.7.** The *quiverized Clifford algebra* is

$$Q_{B_l, m-l}(C) = Q(C)/(e_\alpha)_{\alpha \notin B_l, m-l},$$

where  $e_\alpha$  denotes the idempotent corresponding to  $\alpha$ . □

To show that the quiverized Clifford algebra is isomorphic to the non-commutative desingularization, we define a left action on the tilting bundle  $\mathcal{N} = \bigoplus_{\alpha \in B_l, m-l} p'^* L^\alpha \mathcal{Q}$ .

**Proposition A.8.** There is a ring homomorphism  $\Theta: Q_{B_l, m-l}(C) \rightarrow A = \text{End}_{\mathcal{O}_{\mathcal{Z}}}(\mathcal{N})$ . □

**Proof.** Pulling back the tautological quotient map  $\pi^* F^\vee \rightarrow \mathcal{Q}$  from  $\mathbb{G}$  to  $\mathcal{Z}$  and tensoring with  $U$ , we obtain a map

$$\Phi^U: q'^*(F \otimes S)^\vee \otimes U \rightarrow p'^* \mathcal{Q} \otimes U.$$

Similarly, the fact that  $\mathcal{Z} = \text{Spec}(\text{Sym}_{\mathcal{O}_{\mathbb{G}}}(\mathcal{Q} \otimes G))$  yields a tautological map  $p'^* \mathcal{Q} \otimes q'^*(G \otimes S) \rightarrow \mathcal{O}_{\mathcal{Z}}$  which we transform into a map

$$\Psi^U: q'^*(G \otimes S) \otimes U^\vee \rightarrow p'^* \mathcal{Q}^\vee \otimes U^\vee.$$

Now  $\tilde{F}^\vee$  maps to the global sections of  $q'^*(F \otimes S)^\vee \otimes U$  and similarly  $\tilde{G}$  maps to the global sections of  $q'^*(G \otimes S) \otimes U^\vee$ . Thus,  $\tilde{F}^\vee$  acts via the map  $\Phi^U$  on  $\bigwedge_{\mathcal{O}_{\mathcal{Z}}}(p'^* \mathcal{Q} \otimes U)$  by left exterior multiplication, and  $\tilde{G}$  acts via the map  $\Psi^U$  by contraction. It is easy to see that these two actions satisfy the Clifford relations.

Thus,  $C$  acts on  $\bigwedge_{\mathcal{O}_{\mathcal{Z}}}(p'^* \mathcal{Q} \otimes U)$  and hence  $Q(C)$  acts on  $Q^\circ(\bigwedge_{\mathcal{O}_{\mathcal{Z}}}(p'^* \mathcal{Q} \otimes U))$ . By the Cauchy formula, we have

$$\bigwedge_{\mathcal{O}_{\mathcal{Z}}}(p'^* \mathcal{Q} \otimes U) = \bigoplus_{\alpha \in B_l, m-l} L^\alpha \mathcal{Q} \otimes L^{\alpha'} U = \bigoplus_{\alpha \in B_l, m-l} \mathcal{N}_\alpha \otimes L^{\alpha'} U,$$

and hence

$$Q^\circ(\bigwedge_{\mathcal{O}_{\mathcal{Z}}}(p'^* \mathcal{Q} \otimes U)) = \bigoplus_{\alpha \in B_l, m-l} \mathcal{N}_\alpha = \mathcal{N}.$$

Thus,  $Q(C)$  acts on  $\mathcal{N}$  and in fact  $Q_{B_l, m-l}(C)$  acts since  $\bigwedge_{\mathcal{O}_{\mathcal{Z}}}(p'^* \mathcal{Q} \otimes U)$  contains only representations  $L^\alpha \mathcal{Q}$  with weight in  $B_l, m-l$ . ■



To prove that  $\Theta$  is an isomorphism, we must understand  $Q_{B_l, m-l}(C)$  more concretely. The presentation of  $C$  over  $S$  yields a presentation of  $Q(C)$  by Lemma A.3, and hence of  $Q_{B_l, m-l}(C)$ . The generators are easily identified.

**Proposition A.9.** The quiver for  $Q(C)$  has vertices indexed by the transposes  $\alpha'$  of partitions corresponding to representations  $L^\alpha U$ , and has arrows  $\alpha' \longrightarrow \beta'$  indexed by (a basis of)

$$\begin{cases} F^\vee & \text{if } \alpha \nearrow \beta \text{ and} \\ G & \text{if } \beta \nearrow \alpha. \end{cases} \quad \square$$

**Proof.** The Clifford algebra  $C$  is generated by  $\tilde{F}^\vee = F^\vee \otimes U$  and  $\tilde{G} = G \otimes U^\vee$ . We therefore compute the generators of  $Q(C)$  as

$$Q(F^\vee \otimes U)_{\beta'}^{\alpha'} = \text{Hom}_{\text{GL}(U)}(L^\beta U, L^\alpha U \otimes F^\vee \otimes U) = F^\vee \otimes \mathbb{L}_\beta^{1\alpha}$$

and

$$Q(G \otimes U^\vee)_{\beta'}^{\alpha'} = \text{Hom}_{\text{GL}(U)}(L^\beta U, L^\alpha U \otimes G \otimes U^\vee) = G \otimes \mathbb{L}_\beta^{1*\alpha}$$

for two partitions  $\alpha', \beta'$ , where the transposes arise because of our identification  $\alpha \leftrightarrow L^\alpha U$ . These are the natural generators. To have them solely in terms of  $F^\vee$  and  $G$ , one can choose basis elements for the one-dimensional spaces  $\mathbb{L}_\beta^{1\alpha}$  and  $\mathbb{L}_\beta^{1*\alpha}$ . ■

The presentation of  $C$  over  $S$  can be translated into a presentation over the ground field  $K$ . In the case of maximal minors, we saw [5, Remark 7.6] that this presentation involves cubic relations of the form  $\lambda_k(\lambda_i g_j + g_j \lambda_i) = (\lambda_i g_j + g_j \lambda_i) \lambda_k$  and  $g_k(\lambda_i g_j + g_j \lambda_i) = (\lambda_i g_j + g_j \lambda_i) g_k$  expressing the fact that the polynomial ring  $S$  lies in the center of the algebra. We observe that this phenomenon disappears for smaller minors.

**Proposition A.10.** If  $m - l > 1$ , then the Clifford algebra  $C$  is defined by quadratic relations over  $K$ , whence  $Y$  is quadratic as well. □

**Proof.** We have to show that the generators  $x_{ij} = \lambda_i \otimes g_j$  of the polynomial ring are central in  $C$ , using only the quadratic relations. To show that this element commutes with the generators  $\lambda_k \otimes u_a$  and  $g_k \otimes u_a^*$ , fix  $k$  and  $a$  and observe that  $\lambda_k \otimes u_a$  and  $g_k \otimes u_a^*$  each anticommute with any  $\lambda_i \otimes u_b$  and  $g_j \otimes u_b^*$  for any  $b \neq a$ . Since  $m - l > 1$ , we may choose

$b \neq a$ , and then

$$\lambda_i \otimes g_j = (\lambda_i \otimes u_b)(g_j \otimes u_b^*) + (g_j \otimes u_b^*)(\lambda_i \otimes u_b)$$

commutes with  $\lambda_k \otimes u_a$  and  $g_k \otimes u_a^*$ . The consequence that  $Y$  is quadratic follows from Lemma A.3.  $\blacksquare$

We can obtain the relations in  $Q(C)$  by quiverization as well, giving an alternative to Lemma 6.7.

**Proposition A.11.** Assume  $m - l > 1$ . The spaces of relations in  $Q(C)$  between two vertices  $\alpha'$  and  $\gamma'$  are given below.

$$\left\{ \begin{array}{ll} \text{Sym}_2 F^\vee & \text{if } \gamma \nearrow \nearrow \alpha, \text{ two boxes in a column,} \\ \wedge^2 F^\vee & \text{if } \gamma \nearrow \nearrow \alpha, \text{ two boxes in a row,} \\ \text{Sym}_2 F^\vee \oplus \wedge^2 F^\vee \cong F^\vee \otimes F^\vee & \text{if } \gamma \nearrow \nearrow \alpha, \text{ two disconnected boxes,} \\ F^\vee \otimes G & \text{if } \alpha \neq \gamma, \text{ and } \alpha \nearrow \beta, \gamma \nearrow \beta, \text{ some } \beta, \\ (F^\vee \otimes G)^{\oplus(r(\alpha)-1)} & \text{if } \alpha = \gamma, \\ \text{Sym}_2 G & \text{if } \alpha \nearrow \nearrow \gamma, \text{ two boxes in a column,} \\ \wedge^2 G & \text{if } \alpha \nearrow \nearrow \gamma, \text{ two boxes in a row,} \\ \text{Sym}_2 G \oplus \wedge^2 G \cong G \otimes G & \text{if } \alpha \nearrow \nearrow \gamma, \text{ two disconnected boxes.} \end{array} \right.$$

Here  $r(\alpha)$  denotes the number of rows in which a box can be added to  $\alpha$  to obtain a partition.  $\square$

Note that as in Definition 6.5, the embedding in each case is not the obvious diagonal one, but relies on the canonical decompositions (7.1).

We prove the proposition by considering in turn the quiverizations of the three kinds of relations on  $C$ . These are defined by subspaces of the degree-2 part of the tensor algebra  $T_S((\tilde{F}^\vee \oplus \tilde{G}) \otimes S)$ , which decomposes

$$(\tilde{F}^\vee \oplus \tilde{G}) \otimes (\tilde{F}^\vee \oplus \tilde{G}) = (\tilde{F}^\vee \otimes \tilde{F}^\vee) \oplus (\tilde{G} \otimes \tilde{G}) \oplus (\tilde{F}^\vee \otimes \tilde{G}) \oplus (\tilde{F}^\vee \otimes \tilde{G}).$$

### Relations coming from $\tilde{F}^\vee$

In  $C$ , the elements of  $\tilde{F}^\vee$  anticommute; equivalently, the relations defining  $C$  include the representation  $\text{Sym}_2(F^\vee \otimes U)$ . Now

$$\text{Sym}_2(F^\vee \otimes U) = (\text{Sym}_2 F^\vee \otimes \text{Sym}_2 U) \oplus (\wedge^2 F^\vee \otimes \wedge^2 U)$$

naturally (for definiteness we take the splitting  $\text{Sym}_2 F^\vee \longrightarrow F^\vee \otimes F^\vee$  sending  $\lambda\mu$  to  $\frac{1}{2}(\lambda \otimes \mu + \mu \otimes \lambda)$ ). So in fact we have two types of relations  $\text{Sym}_2 F^\vee \otimes \text{Sym}_2 U$  and  $\wedge^2 F^\vee \otimes \wedge^2 U$ . We discuss these individually.

For the first case, we need to describe the map  $Q(\text{Sym}_2 F^\vee \otimes \text{Sym}_2 U) \longrightarrow Q(\text{Sym}_2 F^\vee) \otimes Q(\text{Sym}_2 U)$ . Specializing to two vertices  $\alpha', \gamma'$ , we need to describe the induced map

$$\begin{aligned} \text{Sym}_2 F^\vee \otimes \mathbb{L}_\gamma^{[2]\alpha} &= Q(\text{Sym}_2 F^\vee \otimes \text{Sym}_2 U)_{\gamma'}^{\alpha'} \\ &\longrightarrow \bigoplus_{\beta'} Q(F^\vee \otimes U)_{\gamma'}^{\beta'} \otimes Q(F^\vee \otimes U)_{\alpha'}^{\gamma'} \\ &= \bigoplus_{\beta'} F^\vee \otimes \mathbb{L}_\gamma^{1\beta} \otimes F^\vee \otimes \mathbb{L}_\beta^{1\alpha} \\ &= F^\vee \otimes F^\vee \otimes \mathbb{L}_\gamma^{11\alpha}. \end{aligned}$$

The map on the  $F^\vee$  factors is the natural one  $\text{Sym}_2 F^\vee \longrightarrow F^\vee \otimes F^\vee$ , as we have not really touched  $F^\vee$ . The inclusion map  $\mathbb{L}_\gamma^{[2]\alpha} \longrightarrow \mathbb{L}_\gamma^{11\alpha}$  is obtained from the canonical decomposition

$$\mathbb{L}_\gamma^{11\alpha} = (\mathbb{L}_{[2]}^{11} \otimes \mathbb{L}_\gamma^{[2]\alpha}) \oplus (\mathbb{L}_{[11]}^{11} \otimes \mathbb{L}_\gamma^{[11]\alpha}).$$

There are three essentially different possibilities for  $\alpha', \gamma'$ .

- (i)  $\gamma'$  is obtained from  $\alpha'$  by adding two boxes to a row. In this case, there is a unique  $\beta'$  such that  $\alpha' \nearrow \beta' \nearrow \gamma'$ . By the Littlewood–Richardson rule, we have  $\mathbb{L}_\gamma^{[11]\alpha} = 0$  and hence

$$\mathbb{L}_\gamma^{11\alpha} = \mathbb{L}_\gamma^{[2]\alpha} = \mathbb{L}_\gamma^{1\beta} \otimes \mathbb{L}_\beta^{1\alpha}.$$

The corresponding relations are given by

$$\text{Sym}_2 F^\vee \otimes \mathbb{L}_\gamma^{1\beta} \otimes \mathbb{L}_\beta^{1\alpha} \hookrightarrow (F^\vee \otimes \mathbb{L}_\gamma^{1\beta}) \otimes (F^\vee \otimes \mathbb{L}_\beta^{1\alpha}).$$

Thus, for  $\alpha' \nearrow \beta' \nearrow \gamma'$  with the boxes being added in the same row the relations are the *anti-commutation relations*.

- (ii)  $\gamma'$  is obtained from  $\alpha'$  by adding two boxes to a column. In this case,  $\mathbb{L}_\gamma^{[2]\alpha} = 0$  and hence there are no such relations.
- (iii)  $\gamma'$  is obtained from  $\alpha'$  by adding two boxes not in the same row or column. In this case, there are distinct  $\beta'_1, \beta'_2$  such that  $\alpha' \nearrow \beta'_1 \nearrow \gamma', \alpha' \nearrow \beta'_2 \nearrow \gamma'$ . The corresponding relations are now relations between paths going

$$\alpha' \longrightarrow \beta'_1 \longrightarrow \gamma' \text{ and } \alpha' \longrightarrow \beta'_2 \longrightarrow \gamma':$$

$$\text{Sym}_2 F^\vee \otimes \mathbb{L}_\gamma^{[2]\alpha} \hookrightarrow (F^\vee \otimes \mathbb{L}_\gamma^{1\beta_1}) \otimes (F^\vee \otimes \mathbb{L}_{\beta_1}^{1\alpha}) \oplus (F^\vee \otimes \mathbb{L}_\gamma^{1\beta_2}) \otimes (F^\vee \otimes \mathbb{L}_{\beta_2}^{1\alpha}).$$

Now we describe the relations on  $Q(C)$  derived from the inclusion

$$\wedge^2 F^\vee \otimes \wedge^2 U \longrightarrow (F^\vee \otimes U) \otimes (F^\vee \otimes U).$$

Applying  $Q(-)_{\gamma'}^{\alpha'}$  to both sides yields

$$\begin{aligned} \wedge^2 F^\vee \otimes \mathbb{L}_\gamma^{[11]\alpha} &= Q(\wedge^2 F^\vee \otimes \wedge^2 U)_{\gamma'}^{\alpha'} \\ &\longrightarrow \bigoplus_{\beta'} Q(F^\vee \otimes U)_{\gamma'}^{\beta'} \otimes Q(F^\vee \otimes U)_{\beta'}^{\alpha'} \\ &= \bigoplus_{\beta'} F^\vee \otimes \mathbb{L}_\gamma^{1\beta} \otimes F^\vee \otimes \mathbb{L}_\beta^{1\alpha} \\ &= F^\vee \otimes F^\vee \otimes \mathbb{L}_\gamma^{11\alpha}. \end{aligned}$$

We discuss again the possible cases.

- (i)  $\gamma'$  is obtained from  $\alpha'$  by adding two boxes to a row. In this case,  $\mathbb{L}_\gamma^{[11]\alpha} = 0$  and hence there are no such relations.
- (ii)  $\gamma'$  is obtained from  $\alpha'$  by adding two boxes to a column. In this case, there is again a unique  $\beta'$  such that  $\alpha' \nearrow \beta' \nearrow \gamma'$ . The corresponding relations are

$$\wedge^2 F^\vee \otimes \mathbb{L}_\gamma^{1\beta} \otimes \mathbb{L}_\beta^{1\alpha} \hookrightarrow (F^\vee \otimes \mathbb{L}_\gamma^{1\beta}) \otimes (F^\vee \otimes \mathbb{L}_\beta^{1\alpha}).$$

Thus, for  $\alpha' \nearrow \beta' \nearrow \gamma'$  with the boxes being added in the same column the relations are the *commutation relations*.

- (iii)  $\gamma'$  is obtained from  $\alpha'$  by adding two boxes not in the same row or column. In this case, there are distinct  $\beta'_1, \beta'_2$  such that  $\alpha' \nearrow \beta'_1 \nearrow \gamma', \alpha' \nearrow \beta'_2 \nearrow \gamma'$ . The corresponding relations are now relations between paths going  $\alpha' \longrightarrow \beta'_1 \longrightarrow \gamma'$  and  $\alpha' \longrightarrow \beta'_2 \longrightarrow \gamma'$ :

$$\wedge^2 F^\vee \otimes \mathbb{L}_\gamma^{[11]\alpha} \longrightarrow (F^\vee \otimes \mathbb{L}_\gamma^{1\beta_1}) \otimes (F^\vee \otimes \mathbb{L}_{\beta_1}^{1\alpha}) \oplus (F^\vee \otimes \mathbb{L}_\gamma^{1\beta_2}) \otimes (F^\vee \otimes \mathbb{L}_{\beta_2}^{1\alpha}).$$

### Relations coming from $\tilde{G}$

Next we discuss the relations on  $Q(C)$  coming from the inclusion

$$\text{Sym}_2(G \otimes U^\vee) \subseteq (G \otimes U^\vee) \otimes (G \otimes U^\vee).$$

A discussion exactly parallel to the one above, using the identity  $Q(G \otimes U^\vee)_{\gamma'}^{\beta'} = G \otimes \mathbb{L}_\gamma^{1^*\beta}$ , leads to the following cases.

- (i)  $\gamma'$  is obtained from  $\alpha'$  by deleting two boxes from a row. Here there is a unique  $\beta'$  such that  $\gamma' \nearrow \beta' \nearrow \alpha'$ . We find  $\mathbb{L}_\gamma^{[11]^*\alpha} = 0$  and hence  $\mathbb{L}_\gamma^{[2]^*\alpha} = \mathbb{L}_\gamma^{1^*\beta} \otimes \mathbb{L}_\beta^{1^*\alpha}$ . This leads to the inclusion

$$\mathrm{Sym}_2 G \otimes \mathbb{L}_\gamma^{1^*\beta} \otimes \mathbb{L}_\beta^{1^*\alpha} \hookrightarrow (G \otimes \mathbb{L}_\gamma^{1^*\beta}) \otimes (G \otimes \mathbb{L}_\beta^{1^*\alpha}),$$

so we obtain the *anti-commutation relations*.

- (ii)  $\gamma'$  is obtained from  $\alpha'$  by deleting two boxes from a column. In this case, there is again a unique  $\beta'$  such that  $\alpha' \nearrow \beta' \nearrow \gamma'$ . We find the corresponding relations

$$\wedge^2 G \otimes \mathbb{L}_\gamma^{1^*\beta} \otimes \mathbb{L}_\beta^{1^*\alpha} \hookrightarrow (G \otimes \mathbb{L}_\gamma^{1^*\beta}) \otimes (G \otimes \mathbb{L}_\beta^{1^*\alpha}),$$

that is, the *commutation relations*.

- (iii)  $\gamma'$  is obtained from  $\alpha'$  by deleting two boxes not in the same row or column. There are now two distinct  $\beta'_1, \beta'_2$  such that  $\alpha' \nearrow \beta'_1 \nearrow \gamma', \alpha' \nearrow \beta'_2 \nearrow \gamma'$ . The corresponding relations are now relations between paths going  $\alpha' \rightarrow \beta'_1 \rightarrow \gamma'$  and  $\alpha' \rightarrow \beta'_2 \rightarrow \gamma'$ :

$$\mathrm{Sym}_2 G \otimes \mathbb{L}_\gamma^{[2]^*\alpha} \hookrightarrow (G \otimes \mathbb{L}_\gamma^{1^*\beta_1}) \otimes (G \otimes \mathbb{L}_{\beta_1}^{1^*\alpha}) \oplus (G \otimes \mathbb{L}_\gamma^{1^*\beta_2}) \otimes (G \otimes \mathbb{L}_{\beta_2}^{1^*\alpha})$$

and

$$\wedge^2 G \otimes \mathbb{L}_\gamma^{[11]^*\alpha} \longrightarrow (G \otimes \mathbb{L}_\gamma^{1^*\beta_1}) \otimes (G \otimes \mathbb{L}_{\beta_1}^{1^*\alpha}) \oplus (G \otimes \mathbb{L}_\gamma^{1^*\beta_2}) \otimes (G \otimes \mathbb{L}_{\beta_2}^{1^*\alpha}).$$

### Mixed relations

Finally, we discuss the anti-commutativity relations between  $F^\vee \otimes U$  and  $G \otimes U^\vee$ . They are defined by the image of the map defined by the identity, the swap, and the trace:

$$(F^\vee \otimes U) \otimes (G \otimes U^\vee) \xrightarrow{\begin{bmatrix} \mathrm{id} \\ \tau \\ -\mathrm{Tr} \end{bmatrix}} \begin{array}{c} (F^\vee \otimes U) \otimes (G \otimes U^\vee) \\ \oplus \\ (G \otimes U^\vee) \otimes (F^\vee \otimes U) \\ \oplus \\ (F^\vee \otimes G) \end{array}. \quad (\text{A.1})$$

The summands on the right-hand side are living in the obvious places in the tensor algebra  $T_S((\tilde{F}^\vee \oplus \tilde{G}) \otimes S)$ ; in particular, the third summand sits inside the degree zero part of the tensor algebra, which is  $S$ .

We apply  $Q(-)_{\gamma'}^{\alpha'}$  to the components of (A.1), using the canonical isomorphisms

$$\mathbb{L}_\gamma^{11^*\alpha} \cong \bigoplus_{\beta'} \mathbb{L}_\gamma^{1\beta} \otimes \mathbb{L}_\beta^{1^*\alpha}, \quad (\text{A.2})$$

$$\mathbb{L}_\gamma^{11^*\alpha} \cong \bigoplus_{\beta'} \mathbb{L}_\gamma^{1^*\beta} \otimes \mathbb{L}_\beta^{1\alpha}. \quad (\text{A.3})$$

We see first that if  $\alpha \neq \gamma$ , then the third component of the target vanishes:

$$Q(F^\vee \otimes G)_{\gamma'}^{\alpha'} = F^\vee \otimes G \otimes \mathbb{L}_\gamma^\alpha = 0$$

since  $\mathbb{L}_\gamma^\alpha = \delta_{\alpha,\gamma} K$ . Therefore, when  $\alpha \neq \gamma$  the direct sums appearing in the quiverizations of the first two components

$$\begin{aligned} F^\vee \otimes G \otimes \mathbb{L}_\gamma^{11^*\alpha} &= Q(F^\vee \otimes U \otimes G \otimes U^\vee)_{\gamma'}^{\alpha'} \\ &\longrightarrow \bigoplus_{\beta'} Q(F^\vee \otimes U)_{\gamma'}^{\beta'} \otimes Q(G \otimes U^\vee)_{\beta'}^{\alpha'} \\ &= \bigoplus_{\beta'} (F^\vee \otimes \mathbb{L}_\gamma^{1\beta}) \otimes (G \otimes \mathbb{L}_\beta^{1^*\alpha}) \end{aligned}$$

and

$$\begin{aligned} F^\vee \otimes G \otimes \mathbb{L}_\gamma^{11^*\alpha} &= Q(F^\vee \otimes U \otimes G \otimes U^\vee)_{\gamma'}^{\alpha'} \\ &\longrightarrow \bigoplus_{\beta'} Q(G \otimes U^\vee)_{\gamma'}^{\beta'} \otimes Q(F^\vee \otimes U)_{\beta'}^{\alpha'} \\ &= \bigoplus_{\beta'} (G \otimes \mathbb{L}_\gamma^{1^*\beta}) \otimes (F^\vee \otimes \mathbb{L}_\beta^{1\alpha}) \end{aligned}$$

have exactly one summand each, and are thus of the form

$$F^\vee \otimes G \otimes \mathbb{L}_\gamma^{11^*\alpha} \longrightarrow (F^\vee \otimes \mathbb{L}_\gamma^{1\beta_1}) \otimes (G \otimes \mathbb{L}_{\beta_1}^{1^*\alpha})$$

and

$$F^\vee \otimes G \otimes \mathbb{L}_\gamma^{11^*\alpha} \longrightarrow (G \otimes \mathbb{L}_{\beta_2}^{1^*\alpha}) \otimes (F^\vee \otimes \mathbb{L}_{\beta_2}^{1\alpha})$$

for some partitions  $\beta_1, \beta_2$  with  $\beta'_1 \nearrow \alpha' \nearrow \beta'_2$  and  $\beta'_1 \nearrow \gamma' \nearrow \beta'_2$ . The image in this case is thus  $F^\vee \otimes G$ .

If  $\alpha = \gamma$ , then we discard the degree-zero relations expressing the orthogonality of the idempotents corresponding to the vertices and need only consider the image of  $F^\vee \otimes G \otimes \text{Tr}_0 U$  in  $(F^\vee \otimes U) \otimes (G \otimes U^\vee) \oplus (G \otimes U^\vee) \otimes (F^\vee \otimes U)$ , where  $\text{Tr}_0 U = \ker(\text{Tr}: U^\vee \otimes U \rightarrow K)$ . The direct sums appearing in (A.2) and (A.3) have one non-zero summand for each partition  $\beta'$  such that  $\alpha' \nearrow \beta'$  and  $\beta'$  has at most  $m - l$  rows (so that  $L^{\beta'} U \neq 0$ ). That is, they have  $t(\alpha)$  direct summands. Since  $\mathbb{L}_\alpha^{11^* \alpha} = K \oplus \text{Tr}_0 U$ , the image of  $F^\vee \otimes G \otimes \text{Tr}_0 U$  is  $(F^\vee \otimes G)^{\oplus(t(\alpha)-1)}$ .

Arguments parallel to those in Lemma 6.7 and Theorem 6.9 now prove the following.

**Theorem A.12.** The homomorphism  $Q_{Bl, m-l}(C) \rightarrow A = \text{End}_{\mathcal{O}_{\mathcal{Z}}}(\mathcal{N})$  is an isomorphism.  $\square$

**Remark A.13.** The description of the non-commutative desingularization as a quiverized Clifford algebra depends essentially on characteristic zero, relying as it does on the canonical direct-sum decompositions of representations of  $\text{GL}(U)$  into irreducibles. In retrospect, it was the fact that the torus  $\text{GL}(1)$  is linearly reductive in all characteristics that allowed us to prove the analogous result for the case of maximal minors in a characteristic-free manner.  $\square$

**Remark A.14.** Using the description above of the non-commutative desingularization as a quiverized Clifford algebra, one can prove an analog of [5, Theorem D], to the effect that  $\mathcal{Z}$  is the fine moduli space for certain representations of the truncated Young quiver. The details are essentially identical to those in [5, Section 8], so we do not pursue this direction further.  $\square$

**References**

- [1] Aguilar, M., S. Gitler, and C. Prieto. *Algebraic Topology from a Homotopical Viewpoint*. Universitext. New York: Springer, 2002. ISBN 0-387-95450-3. Translated from the Spanish by Stephen Bruce Sontz.
- [2] Ballard, M., D. Favero, and L. Katzarkov. "Variation of geometric invariant theory quotients and derived categories." (2012): preprint, <http://arxiv.org/abs/1203.6643>, 63 pp.
- [3] Boffi, G. "The universal form of the Littlewood–Richardson rule." *Advances in Mathematics* 68, no. 1 (1988): 40–63.
- [4] Bondal, A. I. and D. Orlov. "Derived Categories of Coherent Sheaves." *Proceedings of the International Congress of Mathematicians, Vol. II (Beijing, 2002)*, 47–56. Beijing: Higher Education Press, 2002.
- [5] Buchweitz, R.-O., G. J. Leuschke, and M. Van den Bergh. "Non-commutative desingularization of determinantal varieties, I." *Inventiones Mathematicae* 182, no. 1 (2010): 47–115.

- [6] Buchweitz, R.-O., G. J. Leuschke, and M. Van den Bergh. "On the derived category of Grassmannians in arbitrary characteristic." *Compositio Mathematica* (2015): preprint, <http://dx.doi.org/10.1112/S0010437X14008070>.
- [7] Donovan, W. "Grassmannian twists on the derived category via spherical functors." *Proceedings of the London Mathematical Society* 107, no. 5 (2013): 1053–1090.
- [8] Donovan, W. and E. Segal. "Window shifts, flop equivalences and Grassmannian twists." *Compositio Mathematica* 150, no. 6 (2014): 942–78.
- [9] Doubilet, P., G.-C. Rota, and J. Stein. "On the foundations of combinatorial theory. IX. Combinatorial methods in invariant theory." *Studies in Applied Mathematics* 53 (1974): 185–216.
- [10] Fulton, W. *Young Tableaux, with Applications to Representation Theory and Geometry*. London Mathematical Society Student Texts 35. Cambridge: Cambridge University Press, 1997. ISBN 0-521-56144-2; 0-521-56724-6.
- [11] Hartshorne, R. *Algebraic Geometry*. Graduate Texts in Mathematics 52. New York: Springer, 1977. ISBN 0-387-90244-9.
- [12] Hille, L. and M. Van den Bergh. "Fourier–Mukai Transforms." *Handbook of Tilting Theory*, 147–77. London Mathematical Society Lecture Note Series 332. Cambridge: Cambridge University Press, 2007.
- [13] Jucys, A. A. "On the Young operators of symmetric groups." *Litovskii Fizicheskii Sbornik* 6 (1966): 163–80.
- [14] Jucys, A. A. "Factorization of Young's projection operators for symmetric groups." *Litovskii Fizicheskii Sbornik* 11 (1971): 1–10.
- [15] Kapranov, M. M. "On the derived categories of coherent sheaves on some homogeneous spaces." *Inventiones Mathematicae* 92, no. 3 (1988): 479–508.
- [16] Maliakas, M. and P. J. Olver. "Explicit generalized Pieri maps." *Journal of Algebra* 148, no. 1 (1992): 68–85.
- [17] Okounkov, A. and A. Vershik. "A new approach to representation theory of symmetric groups." *Selecta Mathematica (N.S.)* 2, no. 4 (1996): 581–605.
- [18] Olver, P. J. "Differential hyperforms I." 1982, <http://www.math.umn.edu/~olver/>.
- [19] Ottaviani, G. and E. Rubei. "Quivers and the cohomology of homogeneous vector bundles." *Duke Mathematical Journal* 132, no. 3 (2006): 459–508.
- [20] Sam, S. V. "Computing inclusions of Schur modules." *Journal of Software for Algebra and Geometry* 1 (2009): 5–10.
- [21] Sam, S. V. and J. Weyman. "Pieri resolutions for classical groups." *Journal of Algebra* 329 (2011): 222–59. See the revised and augmented version at <http://arxiv.org/abs/0907.4505v5>.
- [22] Van den Bergh, M. "Non-commutative Crepant Resolutions (With Some Corrections)." *The Legacy of Niels Henrik Abel*, 749–70. Berlin: Springer, 2004. <http://arxiv.org/abs/math/0211064>. The updated [2009] version on arXiv has some minor corrections over the published version.



- [23] Van den Bergh, M. "Three-dimensional flops and noncommutative rings." *Duke Mathematical Journal* 122, no. 3 (2004): 423–55.
- [24] Weyman, J. *Cohomology of Vector Bundles and Syzygies*. Cambridge Tracts in Mathematics 149. Cambridge: Cambridge University Press, 2003. ISBN 0-521-62197-6.
- [25] Weyman, J. and G. Zhao. "Noncommutative desingularization of orbit closures for some representations of  $GL_n$ ." (2012): preprint arXiv:1204.0488.